

Specifications for ReGen plant model and control architecture

Agreement no.: PSO ForskEl 12347
Project Name: Ancillary Services from Renewable Power Plants
Acronym: RePlan
Duration: 2015 - 2018
Co-ordinator: DTU Wind Energy

Document information

Document name:	Specifications for ReGen plant model and control architecture
Document number:	D1.1
Contributors:	Lennart Petersen, Müfit Altin, Kamal Shahid, Rasmus L. Olsen, Florin Iov, Anca D. Hansen, Xue Han
Document type:	Deliverable D1.1
Date:	31. 12.2015
WP:	1

Content

Preface.....	5
1 Scope of document.....	1
2 Power System Characterization (Lennart, Florin, Müfit).....	1
2.1 General Architecture (Florin).....	1
2.2 Technical Requirements (Lennart)	5
2.2.1 Operating Limits for Voltage and Frequency.....	7
2.2.2 Voltage Stability Support	8
2.2.3 Frequency Stability Support	11
2.2.4 Active Power Control:.....	16
2.2.5 Rotor Angle Stability Support	17
3 Control Architecture.....	18
3.1 Control Levels (Müfit, Lennart, Florin)	18
3.2 Control Concepts (Florin, Müfit, Lennart, Henrik, Rasmus)	20
3.2.1 Centralized control	20
3.2.2 Decentralized control	21
3.3 Control Coordination (Florin, Müfit, Lennart, Henrik, Rasmus).....	23
3.3.1 Communication Properties (Rasmus)	25
3.3.2 Dispatch Methods (Henrik, Xue).....	29
4 ReGen Plant Control Specifications.....	30
4.1 Voltage/Reactive Power Control (Lennart, Florin)	30
4.1.1 Voltage/Reactive Power Control Design Specifications	30
4.1.2 Voltage/Reactive Power Control Functional Specifications	31
4.2 Frequency Control (Mufit, Anca)	32
4.2.1 Fast frequency response (FFR)	33
4.2.2 Frequency Control	35
4.3 Rotor Angle Stability Support (RSS) (Lennart, Florin, Müfit)	38
4.3.1 RSS Design Specification	38
4.3.2 RSSFunctional Specification.....	38
5 ReGen Models	39
5.1 WTG Model.....	39
5.2 Aggregated WTG Model	40
5.3 WPP Model.....	41

5.4	Aggregated PVP model	43
6	ICT Models	44
6.1	Types of Physical Medium	44
6.1.1	Guided Media:	45
6.1.2	Unguided Media:	45
6.2	Types of Networks based on Switching Techniques	47
6.2.1	Packet Switching:	47
6.2.2	Circuit Switching:	48
6.3	Types of Delays in Packet Switched Networks	48
6.3.1	Processing Delay:	48
6.3.2	Queueing Delay:	48
6.3.3	Transmission Delay:	48
6.3.4	Propagation Delay:	48
6.4	Types of Networks on the Basis of Network Architecture	49
6.4.1	Client-Server Architecture:	49
6.4.2	Peer-to-Peer Architecture:	49
6.5	Types of Networks on the Basis of Scale/Area	49
6.5.1	Local Area Network	49
6.5.2	Metropolitan Area Network	49
6.5.3	Wide Area Network	49
6.6	Types of Networks on the Basis Physical Topologies	49
6.6.1	Bus Topology:	49
6.6.2	Star Topology:	49
6.6.3	Ring Topology:	50
6.6.4	Mesh Topology:	50
6.7	Network Protocols and Layered Architecture	50
6.8	Overview of standard protocols used in context of RePLAN (Kamal)	52
7	Power System Model (Müfit, Lennart, Florin)	53
8	Summary.....	55
9	Bibliography.....	56

Preface

This report is a deliverable in WP1 in the project “Ancillary services from Renewable power Plants” (RePlan). RePlan is funded as POS project 2015 no. 12347 by the Danish PSO-programme ForskEL, which is administered by Energinet.DK. RePlan is carried out in collaboration between DTU Wind Energy, DTU Elektro, Aalborg University Energy Technology, Aalborg University Wireless Communication Networks and Vestas Wind System A/S. DTU Wind Energy is manager of the project.

1 Scope of document

This deliverable report is the backbone of RePlan project, as it defines a generic control framework for the renewable generation (ReGen) plants, as well as the coordination approach between them to provide ancillary services.

The scope of this document is to present the specifications of the ReGen plant model and control architecture used in RePlan project. The report describes the control functions, control architecture (levels, concepts, coordination) as well as the model for aggregated wind power plants (WPPs), photovoltaic plants (PVP) and the power system, including communication properties. Examples for possible coordination between WPPs and PVPs in the provision of each ancillary service (AS) are discussed. Guidelines for the following work-packages as general aiming of RePlan project are summarized at the end of the document. The market and economical regulatory aspects are not in the scope of this document, the focus is mainly kept on technical issues in power systems.

2 Power System Characterization

2.1 General Architecture

Figure 1 defines the general system architecture relevant for RePlan, including the power system structure and its assets, the communication layer and the involved actors having roles and responsibilities for ASs.

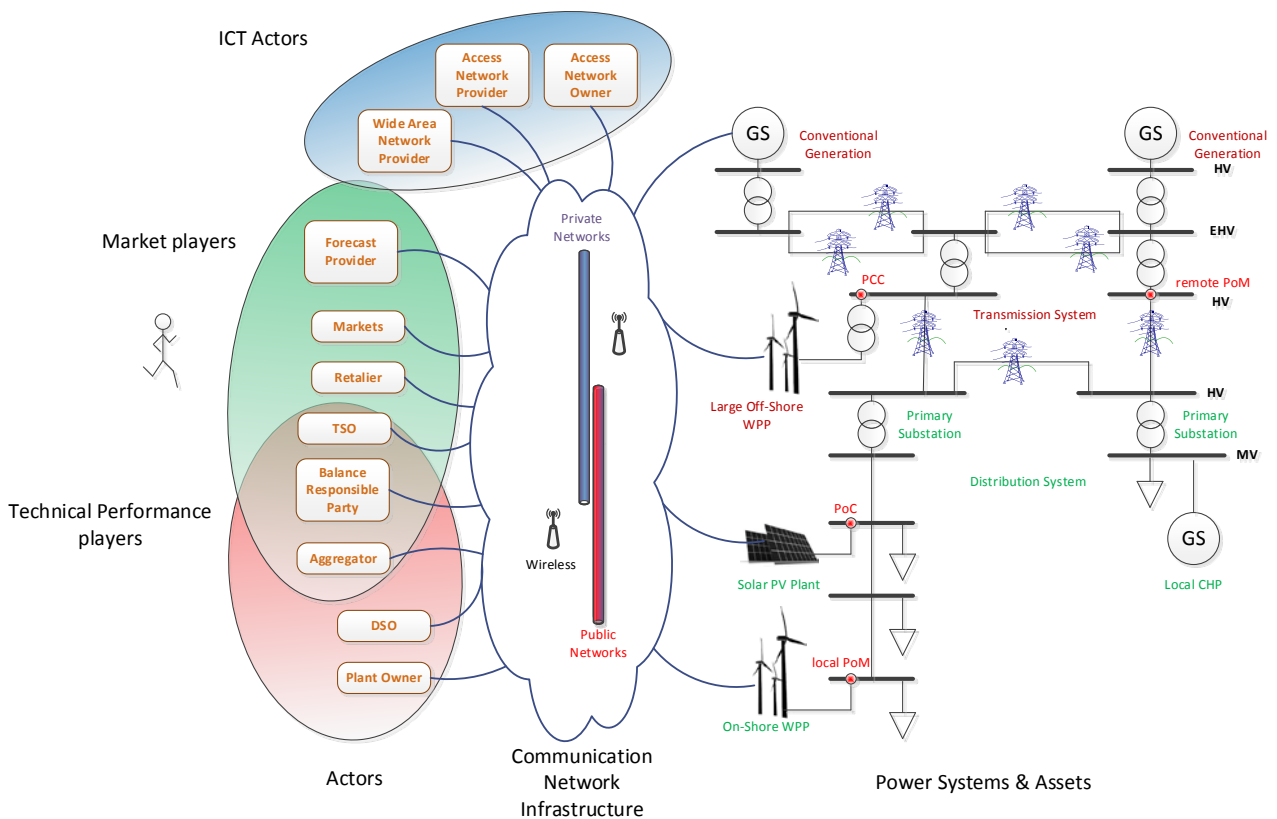


Figure 1. General system architecture including power system & assets, control levels, ICT layer and actors

The power system assets connected to the transmission system and distribution system respectively are colored differently in Figure 1. Following connection and measurement points in the power system are relevant for evaluating ASs of ReGen plants:

- Point of Connection (PoC): The point in the public electricity supply grid, where a plant is or can be connected. All technical requirements outlined in the following section apply to the PoC.
- Point of Common Coupling (PCC): The point in the public electricity supply grid, where consumers are or can be connected. The PCC and the PoC may electrically coincide. The PCC is always located closest to the public electricity supply grid. The voltage reference point for reactive power compensation is either in the PoC or PCC.
- Local Point of Measurement (local PoM): A point in the public electricity supply grid, which is located closest to a particular plant and can be used within the control system for a certain AS to be provided. It can be voltage, power or frequency measurement. The local PoM may electrically coincide with the PoC.
- Remote Point of Measurement (remote PoM): A point in the public electricity supply grid, which is located remotely from any plant and can be used within the control system for a certain AS to be provided. It can be voltage, power or frequency measurement.

The possible capacities of the plants being considered in RePlan are specified according the actual trend of ReGen plants within the transmission system and distribution system respectively:

- Off-Shore WPP: ≥ 25 MW
- On-Shore WPP: ≥ 1.5 MW, ≤ 25 MW
- Solar PV Plant: ≥ 1.5 MW, ≤ 25 MW
- Local CHP: 1.5 MW

The voltage levels are defined according to IEC 61000-3-6 [1] as followed:

- Medium Voltage (MV) ≤ 35 kV
- High Voltage (HV) ≤ 230 kV
- Extra High Voltage (EHV) ≥ 230 kV

All plants and the actors being involved in the provision of ASs are cross-linked through the communication network. The roles and responsibilities of the relevant actors are outlined subsequently.

ICT actors

Access Network Provider (ANP)

Communication between the different entities in the system as illustrated in Figure 1 is critical for the operation of the system. Access networks provide the last mile connection to the different entities involved in the system operation and can rely on both wired and wireless networks. Traditionally wired connection has been the prominent solution due to its inherent reliability, but is usually also very costly due to deployment costs. Wireless embedded machine-to-machine (M2M) solutions for utility automation are becoming increasingly important as a possible solution to connect the involved entities. Leveraging on established connections with end user using wired and wireless connectivity and on cost efficiency for deploying and offering connectivity to distribution system operator (DSO) and transmission system

operator (TSO), the telecommunications companies will be playing an increasingly greater role in common applications such as Automatic Meter Infrastructure, Distribution Automation, Demand Response, supervisory control, data acquisition for SCADA, building management, home energy management and electrical vehicle charging.

The Access Network Provider (ANP) is therefore the operator of the required communication network, i.e., provider of telecommunication services, like wireless access from a controller to the control centre. In addition, the ANP can supply connectivity services to the DSO and TSO for monitoring and managing smart grid equipment. Depending on business conditions, the provided connectivity services could be extended to a deeper integration between the ANP network and its enablers and the DSO/TSO communication network and grid. In this case, ANP can also enable a series of market driver positively affecting the smart grid business case. Alternatively, a DSO could also take the role of ANP themselves, but this requires the DSO to take also responsibilities of proper handling of data in the network.

Business models for driving M2M platforms for access to the different entities are not in the scope of RePlan, as the focus is rather on the impact of using different technologies, wired as well as wireless in the access network and to what extent these technologies can support the different control functionality and under which conditions. Focus will be specifically on both private and public type of network.

Wide Area Network Provider (WNP)

Wide Area Networks provider (WNP) is defined by its ability to provide long range connectivity, and is constructed by several networks in connection to each other. Typically wide area networks (WANs) are provided by tele operators as well as connection to the established Internet (which also can be defined as a WAN). Thus WNP is the operator of the highest level of networks represented by WANs covering large areas. WANs extend beyond the boundaries of the personal space (Personal Area Network - PAN), buildings/premises (Local Area Network - LAN) and cities (Metropolitan Area Network - MAN). Technologies at this level mostly include fibre cables, due to their physically large footprint, which necessitates a medium that can sustain high data-rates over long distances through low attenuation and relatively high resistance against noise. ATM, SONET/SDH, X.25 and Frame Relay are commonly to be found at the backbone of WANs. In most cases for M2M type of traffic this is handled by a single network operator, but co-operation with other companies are also seen in specific cases however with potential complications in the exchange of data packets on the boundaries between the different operators.

In the context of RePlan, complex business or interrelations between different operators as such are out of the scope, but the focus will be on technical aspects, defining and assessing different cases and scenarios for reliably and timely provide the service required in an end to end communication setting. In this regards, the focus will be on end-to-end properties (delay characteristics and packet loss probability) rather on individual communication technologies. At this level, it is assumed that the data traffic flows are stochastic in nature due to the aggregation of data traffic from/to the access networks.

Access Network Owner (ANO)

There is a difference in operating a network and owning the network infrastructure itself. It is a well-known business model that one company is renting out their “copper” to other network providers, where the business is created on the approach which data packets are handled. ANOs are the owners of the communication network on which the ANP operates. Often one entity may overtake both roles. Typically when using another company’s network, there is no or little control of the data packets, and mostly the

best effort traffic can be achieved. Special agreements can though ensure data prioritization, but at a larger cost.

In RePlan project, it is assumed that the operator also owns the network as this gives the most freedom to explore the technological capabilities in the context of RePlan. Furthermore, it simplifies the interaction between actors otherwise needed to be accounted for. At worst, it will be a differentiation between being able to adjust quality of service metrics and not being able to do so, which is most often the case if an operator is renting another company's network for increasing its own coverage and penetration.

Market players

- **3rd Party Forecasting Service:** Beyond technical components assisting the forecasting of supply or demand patterns in the future, external consulting services may be used [2].
- **Wholesale Market:** A (wholesale) market where it is possible to buy and sell energy and demand flexibility, i.e. short-term (day ahead, intraday), long-term, and energy balancing trading.
 - Often operated by “Power Exchange” entity
 - Scheduled energy exchange & flexibilities (e.g. in terms of primary, secondary and tertiary reserves)
 - High transmission capacity required in order to avoid arbitrage business due to different price levels in Control Areas accessing the market
 - Incentives for precise reservation requests, e.g. tailored auction mechanisms
 - Base load and peak load differentiation
 - Trading of intermittent energy resources, e.g., realized in Spanish and US markets¹
 - Trading of local energy flexibilities / local balancing & shorter-term trading are essential new features
 - More dynamicity required esp. for distribution grid resources trading, e.g. in seconds, and supply-demand balancing, e.g. in milliseconds.
 - Higher importance of efficient trading of ASs (flexibilities), i.e. entity requiring flexibility the most should be rewarded with an efficient assignment (requires incentives and suitable auction mechanisms)
- **Retailer (Supplier, Trader):** The retailer is the energy supplier having access to eyeball customers by selling energy to them. It relies on an existing distribution network and the energy trading on the wholesale market. It is responsible for acquiring required resources on the wholesale market and may be confronted with compensation payments in case of unsatisfactory physical delivery.
 - Demand matching dynamicity in minutes (e.g. each 5 minutes) and price dynamicity at ~ 30 minutes to 60 minutes at the minimum. ²
 - More efficient trading may be required with ability to snatch more efficient deals on better metering/ forecasting

¹ http://www.smartpowergeneration.com/spg/discussion/flexibility_is_needed_-_but_th

² National Electricity Market (Australia): <http://eex.gov.au/energy-management/energy-procurement/energy-pricing/how-the-energy-market-operates/>

Players involved in market and technical performance

- **Transmission System Operator (TSO):** According to the Article 2.4 of the Electricity Directive 2009/72/EC (Directive): "a natural or legal person responsible for operating, ensuring the maintenance of and, if necessary, developing the transmission system in a given area and, where applicable, its interconnections with other systems, and for ensuring the long- and short-term (minutes) ability of the system to meet reasonable demands for the transmission of electricity".
- **Balance Responsible Party (BRP):** To help maintain the balance between generation and consumption. A BRP may be an electricity producer, a major consumer, an electricity supplier or a trader. They are tasked with maintaining the quarter-hourly balance between all grid user injections and offtakes for which they, as a BRP, are responsible [3].
- **Energy Aggregator:** Aggregating individual ReGen sources in order to act on (wholesale) markets
 - Representing small actors (like private homes with their PVs) on wholesale market by trading their resources appropriately

Technical performance players:

- **Distribution System Operator (DSO):** According to the Article 2.6 of the Directive: "a natural or legal person responsible for operating, ensuring the maintenance of and, if necessary, developing the distribution system in a given area and, where applicable, its interconnections with other systems and for ensuring the long-term ability of the system to meet reasonable demands for the distribution of electricity". The DSO is now responsible for two-directional power flows and regional grid access for ReGen plants, grid stability, efficient integration/regulation of renewables at the distribution level and regional load balancing for the case of smart grids. The DSO has central responsibility for maintaining the stability and power quality in the distribution grid. Under changed regulatory constraints, DSOs may aim at directly controlling local demand and supply, offered as a special service. The costs for maintaining the power quality may also be diversified based on the new role of local supply or trading (supply incentives; retailers compensation etc.) facilitating DSOs in active control of power lines and flows in the distribution grid.
 - Pricing updates (incentives) e.g. in milliseconds for balancing parts of the distribution network
- **Owners / Operators of Energy Generators / ReGen Plants:** Power plants and small energy generators (e.g. WTGs or PVs) producing the energy to be delivered to customers or traded on markets.

2.2 Technical Requirements

The RePlan project takes the ENTSO-E Network Code (NC) for Requirements for Grid Connection Applicable for all Generators (RfG) [4] as a reference document. However, the NC RfG leaves many of the requirements open for detailed specification at national level in terms of non-exhaustive requirements [5]. In these cases, in RePlan project, the detailed requirements will be taken from the Danish regulations for grid connections with detailed specifications for wind [6] and PV [7]. Regarding primary and secondary

frequency control functions, the ENTSO-E Network Code on Load-Frequency Control and Reserves [8] is regarded.

In the following, the general requirements given by ENTSO-E are contrasted with the detailed requirements stipulated by Energinet.dk. In some categories the requirements are complemented by the Nordel Nordic Grid Code (e.g. for Active Power Control) or other grid code regimes (e.g. for Fast Frequency Response), if the level of specification in [4]- [7] is insufficient or stricter requirements are to be expected in future.

Both ENTSO-E and Energinet.dk distinguish the level of requirements depending on the plant sizing in the way: the larger the plant, the stricter the technical requirements. However, as the number of ReGen sources increases in particular in the distribution grids, one might expect stricter requirements to become applicable for lower plant sizes as well. Hence, the technical requirements for generators larger than 75 MW [4], WPPs and PVPs larger than 25 MW [6] [7] are considered for RePlan project.

The subsequent technical requirements are valid at the Point of Connection (POC) of a generation plant.

2.2.1 Operating Limits for Voltage and Frequency

Voltage and Frequency limits:

The following tables and figures show the minimum time periods during which a power generating module (ENTSO-E) or alternatively WPPs and PVPS (Energinet.dk) must be capable of operating for voltages and frequencies deviating from the reference 1 pu at the connection point without disconnecting from the network.

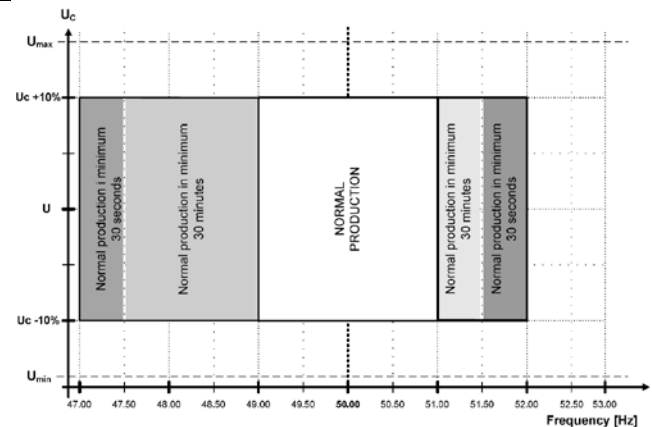
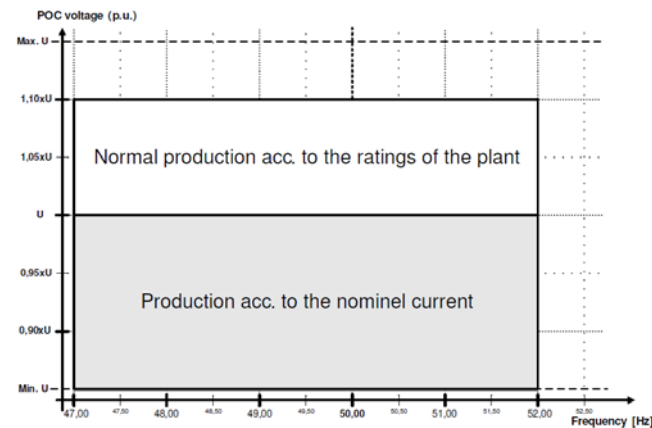
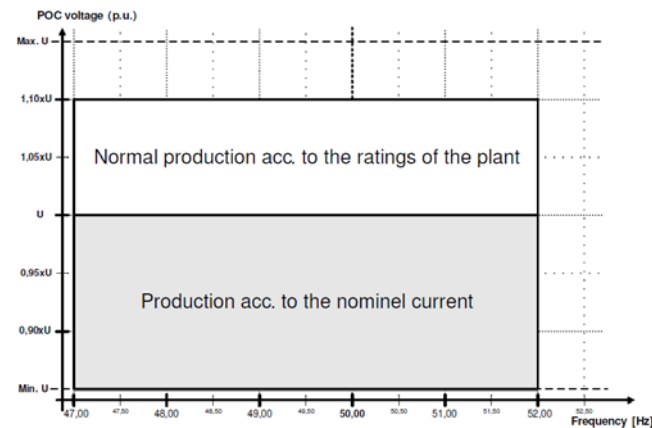
ENTSO-E			Energinet.dk	
Table 1. Operating voltages for 110 kV < V < 300 kV [4]				
Continental Europe	0.85 pu – 0.90 pu	60 minutes		
	0.90 pu – 1.118 pu	Unlimited		
	1.118 pu – 1.15 pu	To be specified by each TSO, but not less than 20 minutes and not more than 60 minutes		
Nordic	0.90 pu – 1.05 pu	Unlimited		
	1.05 pu – 1.10 pu	60 minutes		
Table 2. Operating voltages for 300 kV < V < 400 kV [4]				
Synchronous area	Voltage range	Time period for operation		
Continental Europe	0.85 pu – 0.90 pu	60 minutes		
	0.90 pu – 1.05 pu	Unlimited		
	1.05 pu – 1.10 pu	To be specified by each TSO, but not less than 20 minutes and not more than 60 minutes		
Nordic	0.90 pu – 1.05 pu	Unlimited		
	1.05 pu – 1.10 pu	To be specified by each TSO, but not more than 60 minutes		
Table 3. Operating frequencies [4]				
Synchronous area	Frequency range	Time period for operation		
Continental Europe	47.5 Hz – 48.5 Hz	To be specified by each TSO, but not less than 30 minutes		
	48.5 Hz – 49.0 Hz	To be specified by each TSO, but not less than the period for 47.5 Hz – 48.5 Hz		
	49.0 Hz – 51.0 Hz	Unlimited		
	51.0 Hz – 51.5 Hz	30 minutes		
Nordic	47.5 Hz – 48.5 Hz	30 minutes		
	48.5 Hz – 49.0 Hz	To be specified by each TSO, but not less than 30 minutes		
	49.0 Hz – 51.0 Hz	Unlimited		
	51.0 Hz – 51.5 Hz	30 minutes		

Figure 2. Operating voltages and frequencies for WPPs [6]

Figure 3. Operating voltages and frequencies for PVPs [7]

Protective functions:

The following tables show the required protective functions with associated operating settings and trip time that must be met by WPPs and PVPs in case of violating the previously mentioned voltage and frequency limits.

ENTSO-E	Energinet.dk						
---	Protective function	Symbol	Setting		Trip time		Recommended value
	Overvoltage (step 3)	$U_{>>>}$	$1.20 \cdot U_n$	V	0...100	ms	100 ms
	Overvoltage (step 2)	$U_{>>}$	$1.15 \cdot U_n$	V	100...200	ms	200 ms
	Overvoltage (step 1)	$U_{>}$	$1.10 \cdot U_n$	V	60	s	60 s
	Undervoltage (step 1)	$U_{<}$	$0.90 \cdot U_n$	V	10...60	s	10 s
	Undervoltage (step 2)***)	$U_{<<}$	$0.80 \cdot U_n$	V	50...1500	ms	1500 ms
	Overfrequency	f_s	52	Hz	200	ms	200 ms
	Underfrequency	f_c	47	Hz	200	ms	200 ms
	Change of frequency***)	df/dt	± 2.5	Hz/s	200	ms	200 ms
	***) One of the specified functions must be implemented. Trip time setting values must be in multiples of 50 ms.						
	Figure 4. Requirements for WPPs regarding protective functions [6]						
	Protective function	Symbol	Setting		Trip time		Recommended value
	Overvoltage (step 3)	$U_{>>>}$	$1.20 \cdot U_n$	V	0...100	ms	50 ms
	Overvoltage (step 2)	$U_{>>}$	$1.15 \cdot U_n$	V	100...200	ms	200 ms
	Overvoltage (step 1)	$U_{>}$	$1.10 \cdot U_n$	V	60	s	60 s
	Undervoltage (step 1)	$U_{<}$	$0.90 \cdot U_n$	V	10...60	s	10 s
	Undervoltage (step 2)***)	$U_{<<}$	$0.80 \cdot U_n$	V	50...1500	ms	1500 ms
	Overfrequency	f_s	52	Hz	200	ms	200 ms
	Underfrequency	f_c	47	Hz	200	ms	200 ms
	Change of frequency***)	df/dt	± 2.5	Hz/s	200	ms	200 ms
	***) One of the specified functions must be implemented. Setting values must be in multiples of 50.						
	Figure 5. Requirements for PVPs regarding protective functions [7]						

2.2.2 Voltage Stability Support

The following figures show the required reactive power capability at both maximum capacity and below maximum capacity of a generation plant. For both cases the ENTSO-E defines a fixed outer envelope that must not be exceeded as well as the maximum size of the inner envelope that specifies the reactive power and voltage range. Those requirements apply for the national TSOs to define a valid reactive power capability profile.

Reactive power capability:

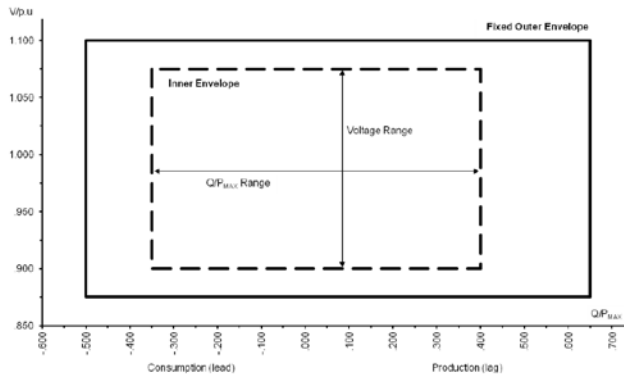
ENTSO-E


Figure 6. U-Q/Pmax-profile [4]

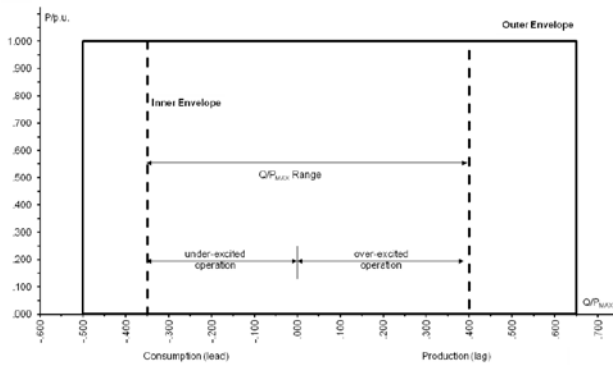


Figure 7. P-Q/Pmax-profile [4]

Synchronous area	Maximum range of Q/P _{max}	Maximum range of steady-state voltage level in PU
Continental Europe	0.75	0.225
Nordic	0.95	0.150

Figure 8. Parameters for the inner envelope of Figure 6 & Figure 7 [4]

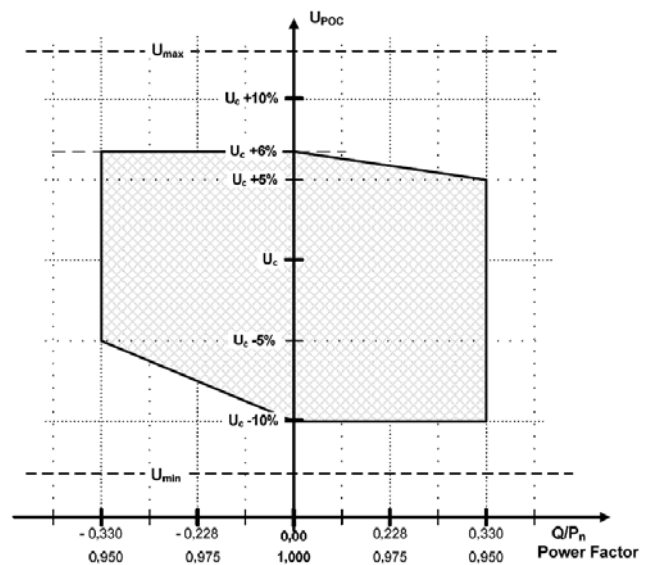
EnergiNet.dk


Figure 9. U-Q/Pmax-profile for WPPs [7]

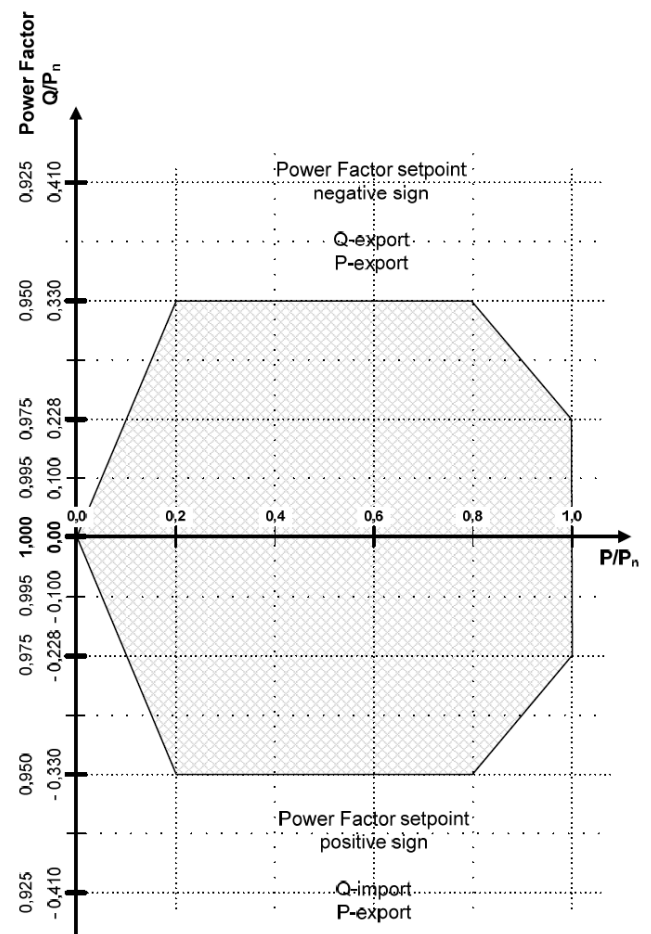


Figure 10. P-Q/Pmax-profile for WPPs [6]

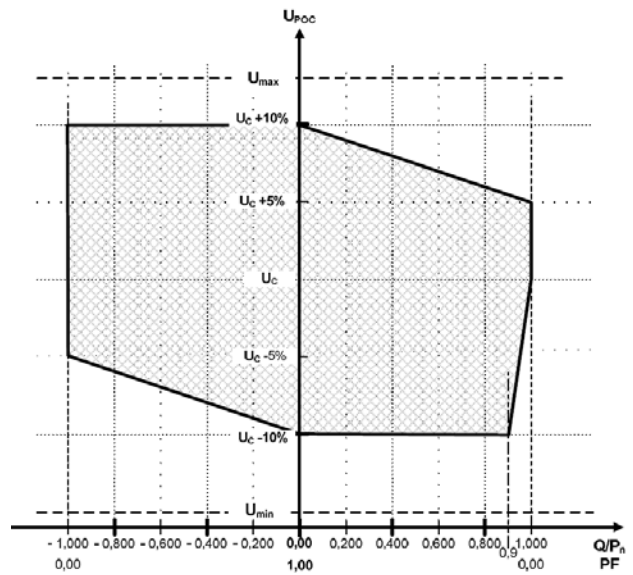


Figure 11. U-Q/Pmax-profile for PVPs [7]

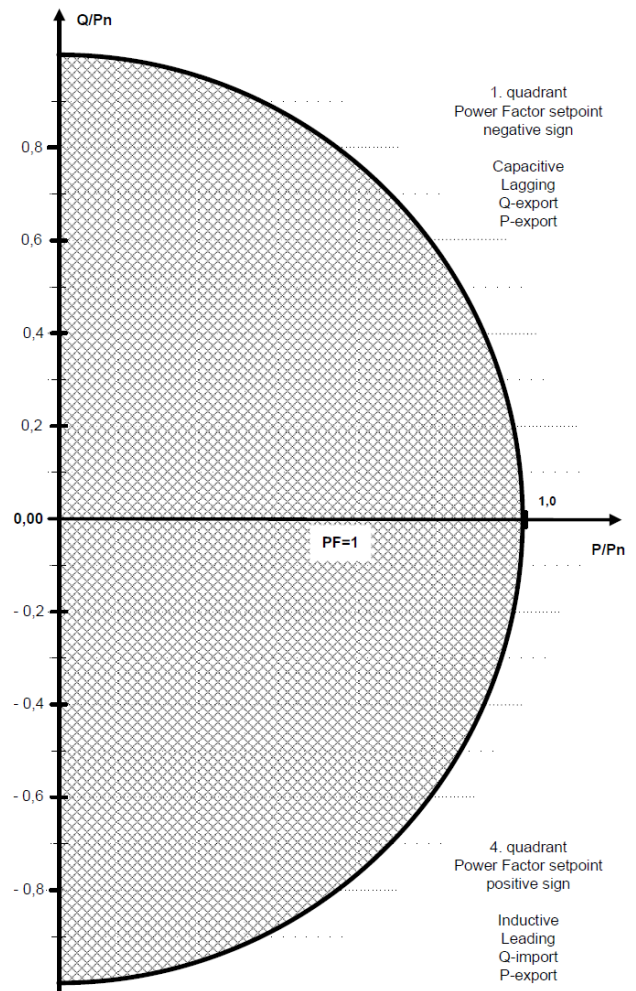


Figure 12. P-Q/Pmax-profile for PVPs [7]

Dynamic reactive power / voltage control:

During normal operation generation plants shall be capable of providing reactive power automatically by either voltage control mode, reactive power control mode or power factor control mode. The technical requirements specify the range of set points, the accuracy of set points and output changes as well as the response times to be fulfilled.

Control mode	ENTSO-E [4]	Energinet.dk
Reactive power	<ul style="list-style-type: none"> - Setting steps no greater than 5 MVar or 5 % (whichever is smaller) - Accuracy of Q output within ± 5 MVar or ± 5 % (whichever is smaller) 	For WPPs [6]: <ul style="list-style-type: none"> - Change of set point must be commenced within 2 sec. and completed no later than 30 sec. after receipt of an order to change the set point - Accuracy of set point: 1 kVar For PVPs [7]: <ul style="list-style-type: none"> - Change of set point must be commenced within 2 sec. and completed no later than 10 sec. after receipt of an order to change the set point - Accuracy of Q output within ± 2 % - Accuracy of set point: 0.1 kVar
Power factor	<ul style="list-style-type: none"> - Setting steps no greater than 0.01 pu 	For WPPs [6]: <ul style="list-style-type: none"> - Change of set point must be commenced within 2 sec. and completed no later than 30 sec. after receipt of an order to change the set point - Accuracy of Q output within ± 2 % - Accuracy of set point: 0.01 For PVPs [7]: <ul style="list-style-type: none"> - Change of set point must be commenced within 2 sec. and completed no later than 10 sec. after receipt of an order to change the set point - Accuracy of Q output within ± 2 % - Accuracy of set point: 0.01
Voltage	<ul style="list-style-type: none"> - Voltage setpoint: 0.95 to 1.05 pu in steps no greater than 0.01 pu - Slope: 2 to 7 % in steps no greater than 0.5 % - Rise time to 90 % of max. Q output: 1 to 5 sec. - Settling time with tolerance of ± 5 % of max. Q output: 5 to 60 sec. 	For WPPs [6] and PVPs [7]: <ul style="list-style-type: none"> - Change of set point must be commenced within 2 sec. and completed no later than 10 sec. after receipt of an order to change the set point - Accuracy of Q output within ± 2 % - Accuracy of set point: 0.5 %

2.2.3 Frequency Stability Support

The technical requirements for frequency stability support (FSS) are separated into the following categories with respect to the Energinet.dk and ENTSO-E technical requirements:

Frequency Response refers to active power responses of renewable generation plants to over frequencies events. Accordingly, frequency control refers to active power regulations by renewable generation plants for frequencies generally deviating from the 50 Hz (mainly under). These definitions are given in Energinet.dk technical requirements [6], [7].

In the ENTSO-E grid code [4], Limited Frequency Sensitive Mode - Overfrequency (LFSM-O) and Underfrequency (LFSM-U) is defined similar to the Frequency Response mentioned in the technical requirements of Energinet.dk. The other definition is related to the frequency control is the Active Power Frequency Response which is both under and over frequency events (corresponding to Frequency Control in the Energinet.dk requirement). Furthermore the maximum frequency deviation, the active power reserves (FCR and FRR) for the frequency control and activation times of these reserves are described in [8]. The requirements are summarized in the following subsections in tables.

2.2.3.1 Frequency Response:

Regarding Frequency Response the frequency threshold, droop settings, active power response times and the measurement accuracy are specified.

ENTSO-E	Energinet.dk
<ul style="list-style-type: none"> - Frequency threshold: 50.2 – 50.5 Hz - Droop setting: 2 – 12 % <p style="text-align: center;"> $s_2 [\%] = 100 \cdot \frac{ \Delta f - \Delta f_1 }{f_n} \cdot \frac{P_{ref}}{ \Delta P } \cdot \frac{ \Delta f }{f_n}$ </p> <ul style="list-style-type: none"> • Synchronous Power Generating Modules: P_{ref} is the Maximum Capacity • Power Park Modules: P_{ref} is the actual Active Power output at the moment the LFSM-O threshold is reached or the Maximum Capacity, as defined by the Relevant TSO <p>Figure 13. Active power response to overfrequencies [4]</p>	<ul style="list-style-type: none"> - Change of active power must be commenced within 2 sec. and completed no later than 15 sec. after a frequency change - Accuracy of frequency measurement: ± 10 mHz - Frequency threshold: 50.00 – 52.00 Hz <p>Figure 14. LFSM-O [6] [7]</p>

2.2.3.2 Frequency Control

Regarding Frequency Control the range of frequency set points, droop settings, active power response times and the measurement accuracy are specified.

ENTSO-E

- Frequency threshold: 49.8 – 49.5 Hz
- Droop setting: 2 – 12 %

Synchronous Power Generating Modules:
 P_{ref} is the Maximum Capacity
 Power Park Modules:
 P_{ref} is the actual Active Power output at the moment the LFSM-U threshold is reached or the Maximum Capacity, as defined by the Relevant TSO

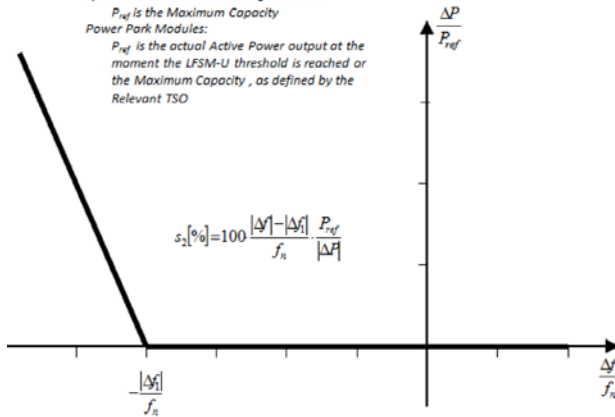


Figure 15. LFSM-U [4]

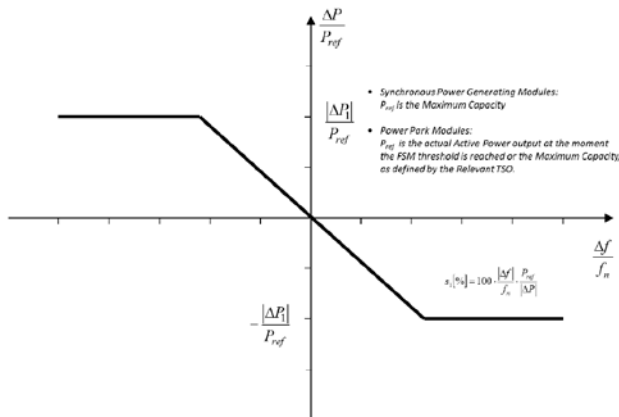


Figure 16. Active power response capability with zero deadband [4]

Table 4. Parameters for active power response capability acc. To Figure 2 [4]

Parameters	Ranges	
Active power range related to maximum capacity $\frac{ \Delta P_1 }{P_{max}}$	1.5 – 10 %	
Frequency response insensitivity	$ \Delta f_i $	10 – 30 mHz
	$\frac{ \Delta f_i }{f_n}$	0.02 – 0.06 %
Frequency response deadband	0 – 500 mHz	
Droop s_1	2 – 12 %	

EnergiNet.dk

- Change of active power must be commenced within 2 sec. and completed no later than 15 sec. after a frequency change
- Accuracy of frequency measurement: ± 10 mHz
- All frequency points in Figure 18 and Figure 19 must be possible to be set within 47.00 – 52.00 Hz

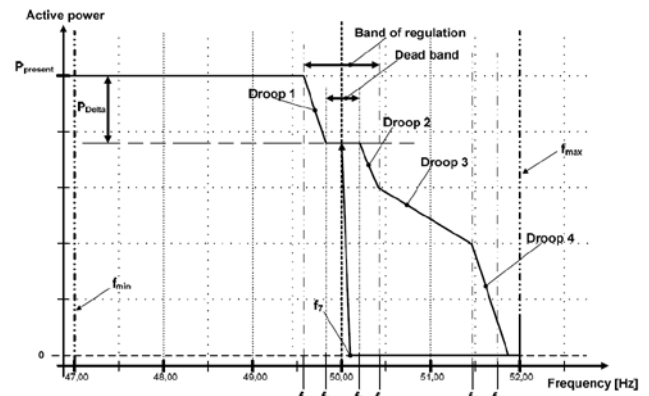


Figure 18. Frequency control for WPPs and PVPs with small downward regulation [6] [7]

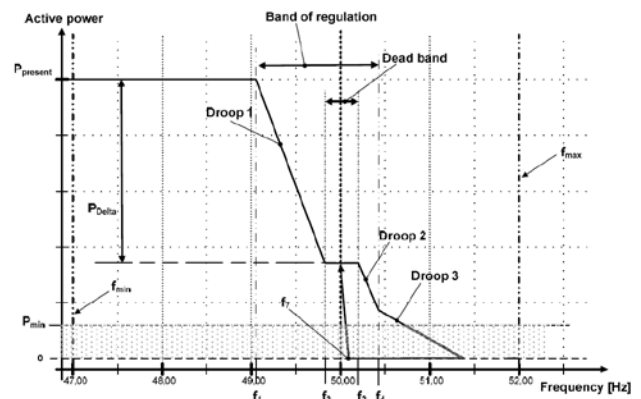


Figure 19. Frequency control for WPPs and PVPs with large downward regulation [6] [7]

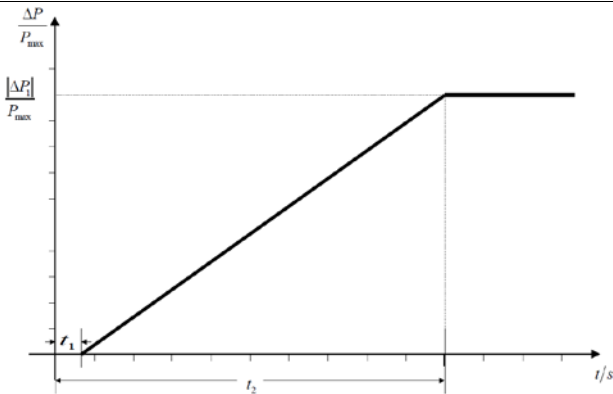


Figure 17. Active power response capability to frequency step changes [4]

Table 5. Parameters for active power response capability to frequency step changes acc. to [4]

Parameters	Ranges or values
Active power range related to maximum capacity (frequency response range) $\frac{ \Delta P }{P_{\max}}$	1.5 – 10%
For power generating modules with inertia, the maximum admissible initial delay t_1 unless justified otherwise in line with Article 15 (2) (d) (iv)	2 seconds
For power generating modules without inertia, the maximum admissible initial delay t_1 unless justified otherwise in line with Article 15 (2) (d) (iv)	as specified by the relevant TSO.
Maximum admissible choice of full activation time t_2 , unless longer activation times are allowed by the relevant TSO for reasons of system stability	30 seconds

2.2.3.3 Frequency Containment Reserve (FCR):

FCR requirements define the frequency quality constraints during primary frequency response, namely standard frequency range, maximum instantaneous frequency deviation and steady-state frequency deviation. Furthermore, the permitted deadband, the accuracy of frequency measurements as well as the full activation time is specified. The Nordic Grid Code requires moreover fast active power responses during larger frequency disturbances outside the normal operating range, referred to “Frequency controlled disturbance reserve”.

ENTSO-E

Table 6. Frequency Quality defining parameters [8]

	CE	GB	IRE	NE
Standard Frequency Range	±50 mHz	±200 mHz	±200 mHz	±100 mHz
Maximum Instantaneous Frequency Deviation	800 mHz	800 mHz	1000 mHz	1000 mHz
Maximum Steady-state Frequency Deviation	200 mHz	500 mHz	500 mHz	500 mHz

Table 7. FCR requirements [8]

Minimum accuracy of frequency measurement	CE, GB, IRE and NE	10 mHz or the industrial standard if better
Maximum combined effect of inherent Frequency Response Insensitivity and possible intentional Frequency Response Dead band of the governor of the FCR Providing Units or FCR Providing Groups.	CE	10 mHz
	GB	15 mHz
	IRE	15 mHz
	NE	10 mHz
FCR Full Activation Time	CE	30 s
	GB	10 s
	IRE	15 s
	NE	30 s if System Frequency is outside Standard Frequency Range
FCR Full Activation Frequency Deviation.	CE	±200 mHz
	GB	±500 mHz
	IRE	Dynamic FCR ±500 mHz Static FCR ±1000 mHz
	NE	±500 mHz

Energinet.dk

- Permitted deadband: ± 20 mHz
- Accuracy of frequency measurements: ± 10 mHz
- Regulation must be maintained for maximally 15 min.
- Following the end of the regulation, the reserve must be re-established after 15 min.

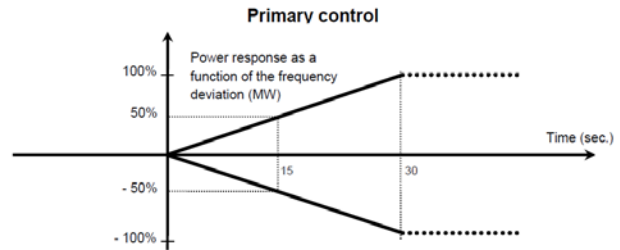


Figure 20. Primary frequency control applicable for Western Danish power system [9]

- Accuracy of frequency measurements: ± 10 mHz
- Regulation must be maintained continuously

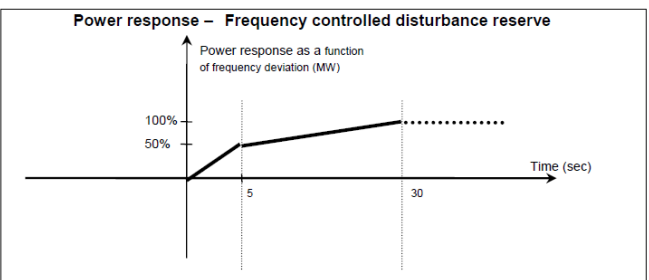
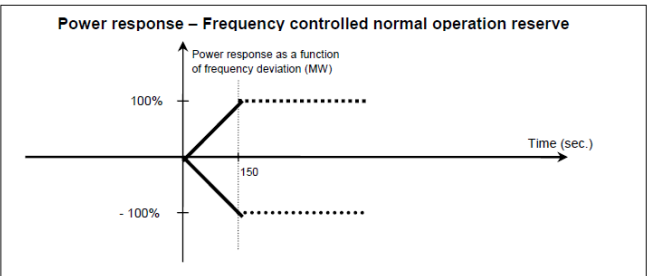
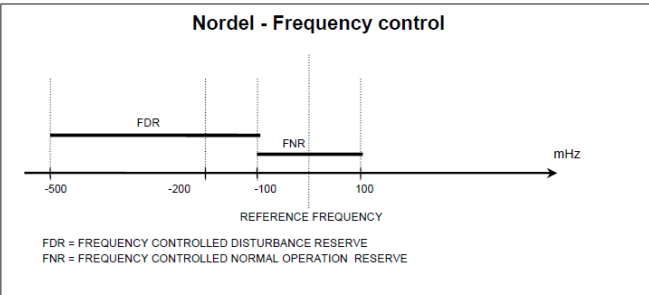


Figure 21. Frequency-controlled normal operation and disturbance reserve applicable for Eastern Danish power system [9]

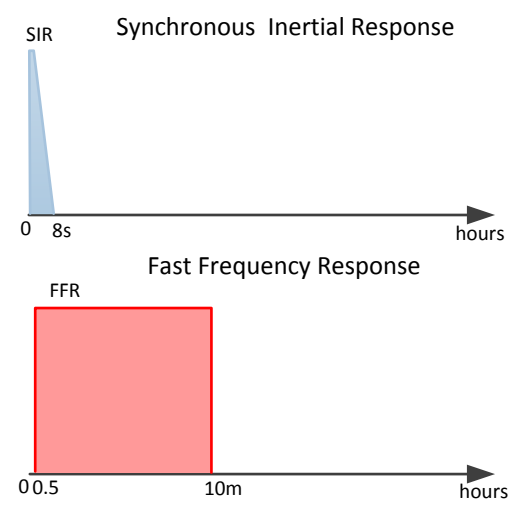
2.2.3.4 Frequency Restoration Reserve (FRR):

FRR requirements refer to activation time of the secondary response reserve.

ENTSO-E [8]	Energinet.dk [10]
<ul style="list-style-type: none"> - Specifications made by national TSO - A FRR providing unit shall have an activation delay of at most 30 sec. 	<ul style="list-style-type: none"> - It must be possible to supply the reserve requested within 15 min.

2.2.3.5 Fast Frequency Response (FFR):

There is only one requirement among the grid codes (from Hydro-Quebec) referring to the activation time, performance, and duration of the inertial response. The other references as presented below are still under investigation by the related TSOs.

National Grid [11]	ERCOT [12]	Hydro-Quebec [13]
<p>To develop and demonstrate an innovative new tool that will measure the RoCoF at a regional level and then enable the initiation of a proportionate, very fast response.</p>		<p>Wind power plants with a rated output greater than 10 MW does the inertial response of a conventional synchronous generator whose inertia (H) equals to 3.5 s. The real power of wind power plants vary dynamically and rapidly by at least 5% for about 10s, when a large, short-duration frequency deviation occurs on the power system..</p>

2.2.4 Active Power Control:

Technical requirements for Active Power Control refer to active power set point changes, related ramping speeds and fast down regulation of active power. Moreover, functions for active power constraint are defined.

Nordel [14]	Energinet.dk
<ul style="list-style-type: none"> - Active power limit of any value with an accuracy of $\pm 5\%$, in the range from 20 % to 100 % of the WPP rated power - Ramping speed of active power production to max. 10 % per minute (upwards & in case of control action downwards) - Fast down regulation from 100 % to 20 % of rated power from the wind turbine in less than 5 sec. 	<ul style="list-style-type: none"> - Downward regulation as continuous or discrete regulation - Discrete regulation must have step size of max. 25 % of the rated power within the hatched area of Figure 22

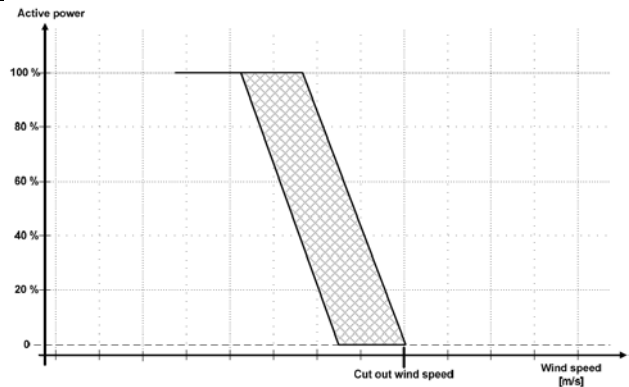


Figure 22. Downward regulation of active power at high wind speeds [6]

Regarding system protection for WPPs and PVPs:

- WPP must have at least 5 different configurable regulation steps
- Recommended steps up to in percent of rated power: 70 % / 50 % / 40 % / 25 % for WPPs & 10 % for PVPs / 0 %
- For downward regulation: shutting-down of individual WTGs is allowed
- Regulation must be commenced within one sec. and completed no later than 10 sec. after receipt of a downward regulation order

Functions for active power constraint:

- Absolute power constraint
- Delta power constraint
- Ramp rate constraint

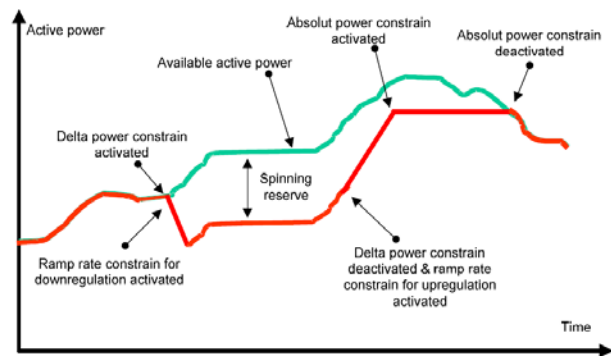
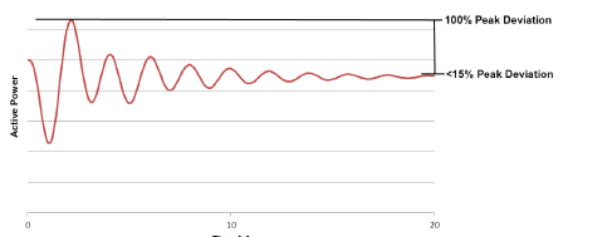


Figure 23. Constraint functions for active power [6] [7]

2.2.5 Rotor Angle Stability Support

Rotor angle stability support (RSS) is not directly mentioned in the grid codes for the ReGen plants. A general recommendation is presented in the ENTSO-E grid code requirements [4]. National Grid in UK has started a project in order to analyze the impact and the requirements of the ReGen plants for the future scenarios. Initial findings showed that there can be a need for some areas in UK that the ReGen plants can contribute the power oscillation damping (POD).

ENTSO-E	National Grid [11]
<p>“with regard to power oscillation damping control, if specified by the relevant TSO a power park module shall be capable of contributing to damping power oscillations. The voltage and reactive power control characteristics of power park modules must not adversely affect the damping of power oscillations.”</p>	<p>The NETS SQSS requires that after a disturbance, the generator should remain synchronised and not experience pole-slipping, and that the initial rotor angle movement should stabilise within 20 seconds following the disturbance.</p>  <p>Figure 24. NETS SQSS Power Oscillation Damping Requirement</p>

3 Control Architecture

In this section the control architecture is described in terms of control levels, control concepts and control coordination. The AS are addressed as specific control functions at different control levels in the system being outlined in Section 3.1. Two different control concepts (Section 3.2) are then presented as examples for the realization of AS provision. Section 3.3 describes the aspect of control coordination including related communication properties as well as possible generic control coordination schemes and dispatch methods for each AS.

3.1 Control Levels

Figure 25 depicts the general control architecture including power system & assets and the following control levels, depicted both for transmission and distribution systems, respectively:

- L2: Control Centre (TSO/DSO)
- L1: Aggregator Control
- L0: Plant Control

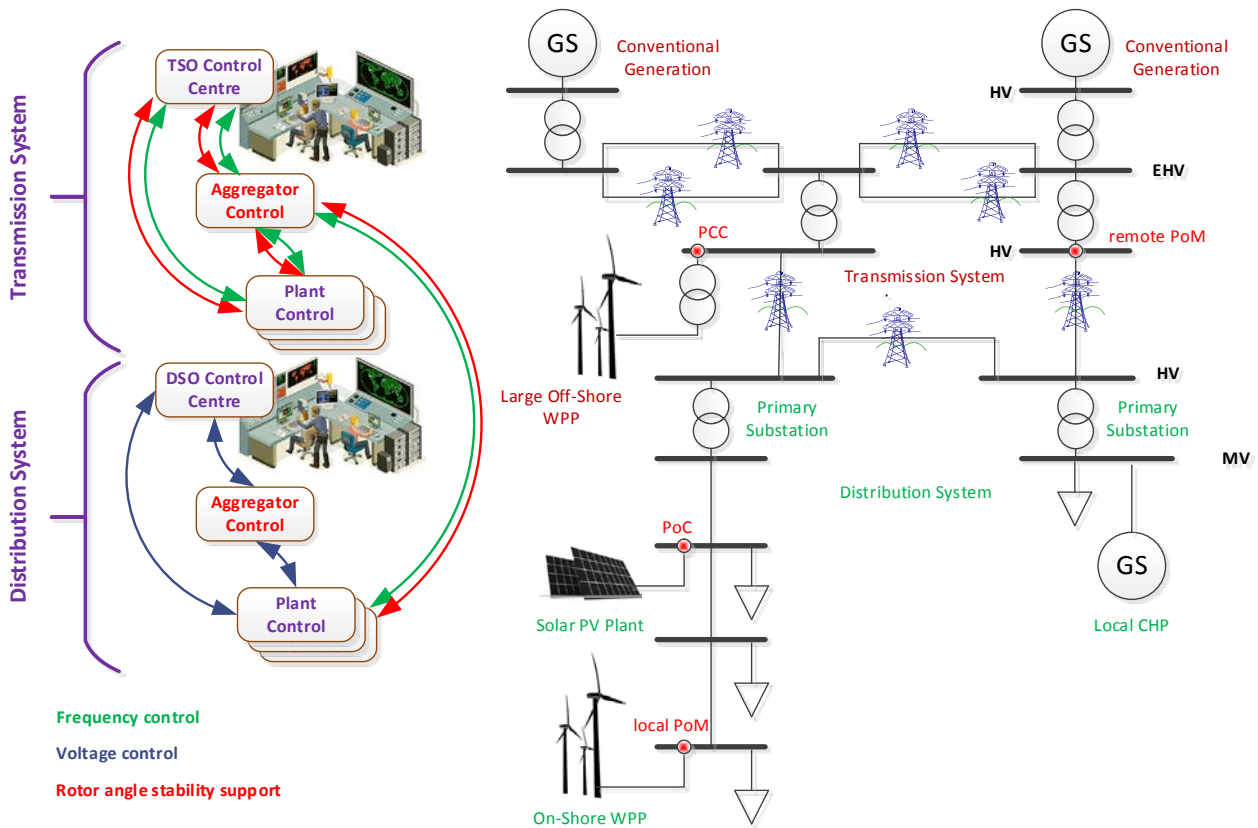


Figure 25. General control architecture including power system & assets and control levels

Three control functions, i.e. frequency control, voltage control and rotor angle stability support, corresponding to the AS in focus in RePlan are indicated by different colors (i.e. green / blue / red) and addressed at their respective control levels. . The different control levels are described as follows:

▪ **L2 - Control Centre**

- **TSO Control Centre** manages the system frequency control as well as its stability by rotor angle stability support. These services can be realized either by direct communication with the power plants in the transmission grid or with the energy aggregators interconnected between TSO and power plants. In RePlan, the power plants in the transmission system are represented by wind power plants (WPPs). Voltage control at transmission level is outside the scope of RePlan. A direct link of the aggregators in the transmission system with the plants in the distribution system is also indicated as a possible solution to investigate.
- **DSO Control Centre** regulates the voltage levels within the distribution grid, either by direct communication with the power plants or by interconnected actors aggregating several power plants of the distribution grid. In RePlan, the power plants in the distribution system can be wind turbines, wind power plants or aggregated photovoltaic PV plants.

▪ **L1 - Aggregator Control**

- **At the transmission level:** it is realized by actors which may aggregate power plants of both transmission and distribution grid. Thereby also plants in the distribution grid can be

incorporated into aggregated control for frequency control and rotor angle stability support.

- **At the distribution level:** it is realized by actors which may aggregate power plants acting exclusively on the distribution level and controlling only voltage levels incorporating locally distributed plants.

- **L0 - Plant Control** level refers to the local control in the power plants and may include all control functions (frequency control, voltage control and rotor angle stability support), as ReGen plants are utilized to contribute to the overall provision of a given AS.

The possible realization of control functions in the various control levels are summarized in the following table as well as by the color-coded arrows in Figure 25, where the possible signal exchange (set-points and measurements) between various control levels is highlighted.

Control Function	Transmission (T)/Distribution Grid (D)	Control Levels
Voltage/Reactive Power Control	D	L2, L1, L0
Frequency Control	T, D	L2, L1, L0
Rotor Angle Stability Support	T, D	L2, L1, L0

3.2 Control Concepts

Two control concepts for AS provision are defined and addressed based on the control architecture depicted in Figure 25, i.e. centralized control and decentralized control.

3.2.1 Centralized control

The centralized control concept, depicted in Figure 26, is based on the current setup used by system operators.

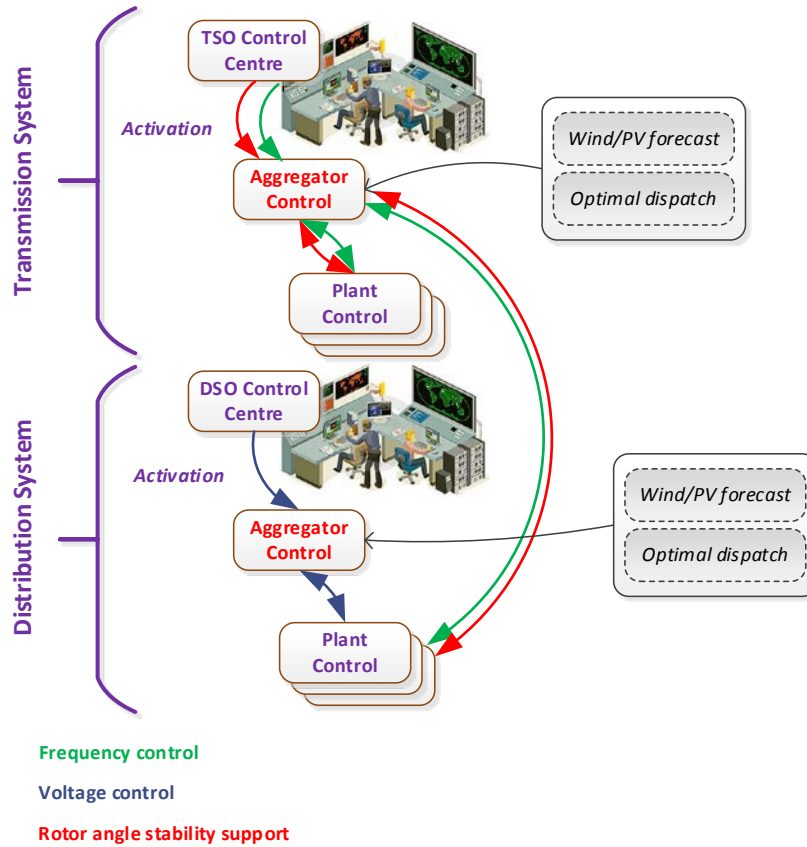


Figure 26. Centralized Control Architecture

Depending on the power system status, the **Control Centre** activates certain control functions on the **Aggregated Control** level acting as the central controller. Optimal dispatch functionality and wind/PV forecast, accounting for the availability of the assets to provide a given AS are included in the aggregated control, as well as the measurements with the status of the assets (WPPs and PVs units). The set points to the WPPs and PVPs are sent by the central controller according to the control and dispatch algorithm. Notice that there might be several central controllers acting in different locations depending on the number of energy aggregators present on the market. A more detailed description of the centralized control concept will be given in section 3.3.

3.2.2 Decentralized control

As illustrated in Figure 27, contrary to the centralized control structure, in the decentralized control concept, there is no communication between assets and no upper hierarchical control level.

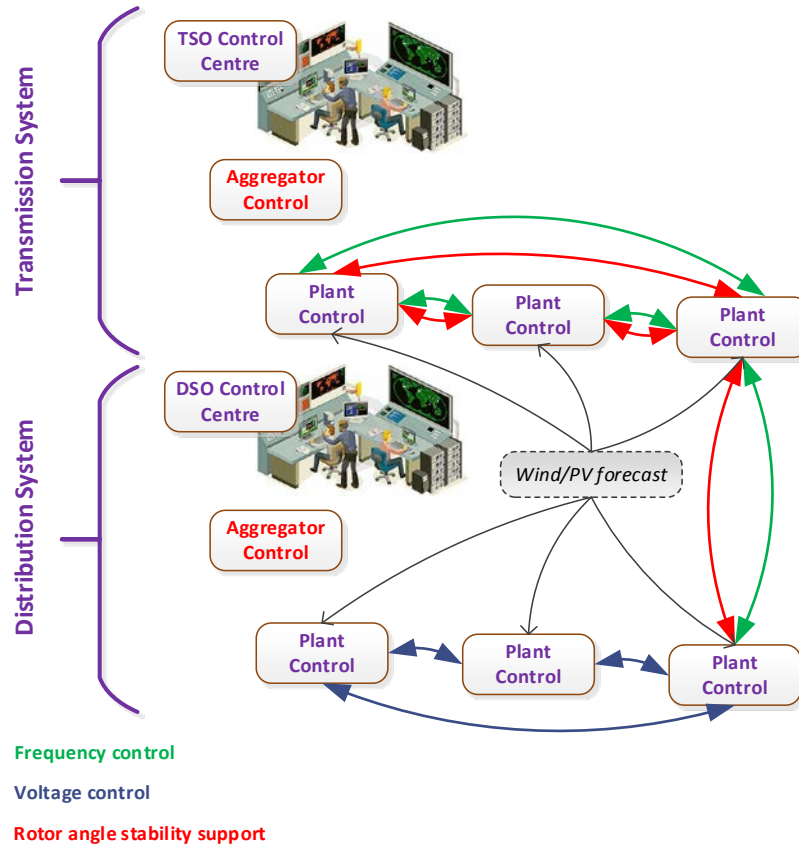


Figure 27. Decentralized Control Architecture

In this control concept, each **Plant Control** (L0) can communicate with the other parallel local plant controllers with predefined characteristics depending on the control phenomena. In order to provide better control performance for a given AS, data exchange between the plants may be necessary. In this way, plants in the transmission system can communicate with each other regarding frequency control and rotor angle stability support, while plants in the distribution system can communicate with each other regarding voltage control. An optional solution can also be that plants in the transmission system communicate with plants in the distribution system to provide better performance regarding frequency control and rotor angle stability support.

In the decentralized control concept, forecast methods can be used for each plant individually to provide a given AS, when feasible. However, optimal dispatch is not feasible for this control concept due to the lack of a centralized control element.

An overview of both control concepts is provided in subsequent table.

Control Concept	Optimal Power Dispatch	Wind/PV forecast	Control Levels
Centralized Control	Yes	Yes	L2, L1, L0
Decentralized Control	No	Yes	L0

3.3 Control Coordination

In the context of RePlan, **coordination** refers to the allocation/scheduling and configuration of functionality of assets to deliver a given AS, taking into account the real time communication, the capabilities and availability of resources.

This section provides and defines an overview of a possible coordination scheme for the centralized control concept, including the whole coordination chain with **Aggregator Control** level and ReGen **Plant Control** level as depicted in Figure 28. The illustrations and the descriptions given in this section are kept generic and illustrative at this stage, as they will be specifically addressed and detailed for each particular AS development in following work packages.

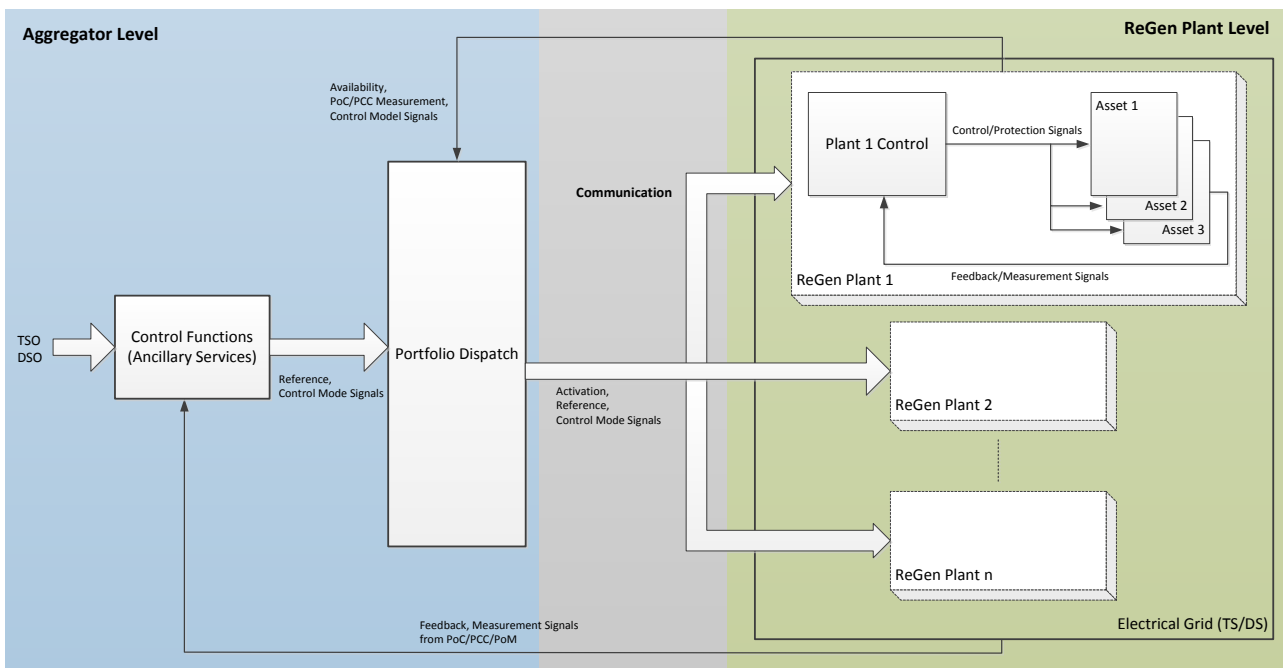


Figure 28. Coordination scheme for AS provision (centralized control concept)

At the **Aggregator Control** level, the system operator (TSO or DSO) can activate specific AS (*Control Functions*) such as secondary voltage/reactive power control, frequency control and power oscillation damping (POD). The *Control Functions* block maintains an overview of the state of the complete portfolio under control. This includes the availability of the individual ReGen plants, their position in the network, their capabilities i.e. which AS they can provide and their current potential service delivery capacity. *Control Functions* block receives information/commands from the TSO/DSO level and decides the allocation of the available ReGen Plants and distributes control parameters according to the service contracts. It further maintains this overview of the portfolio and detects if it is necessary to trigger a re-allocation of the ReGen plants. The specific control functions and their coordination between assets will be defined and exemplified later in the document. According to a contract agreement global setpoints will be sent to a *Portfolio Dispatch* block which will:

- further allocate setpoints to each individual ReGen plant based on an assumption of their availability and capability.

- send activation signals for specific AS, in some circumstances scheduling of plant activation to improve the performance of AS provision.
- change the operating mode of the ReGen plant such as curtailed operation mode, among voltage/reactive power/powerfactor control modes for the sake of AS provision.

Feedback signals from all ReGen plants will be sent back to the dispatcher indicating whether the assets violate the dispatcher’s algorithm.

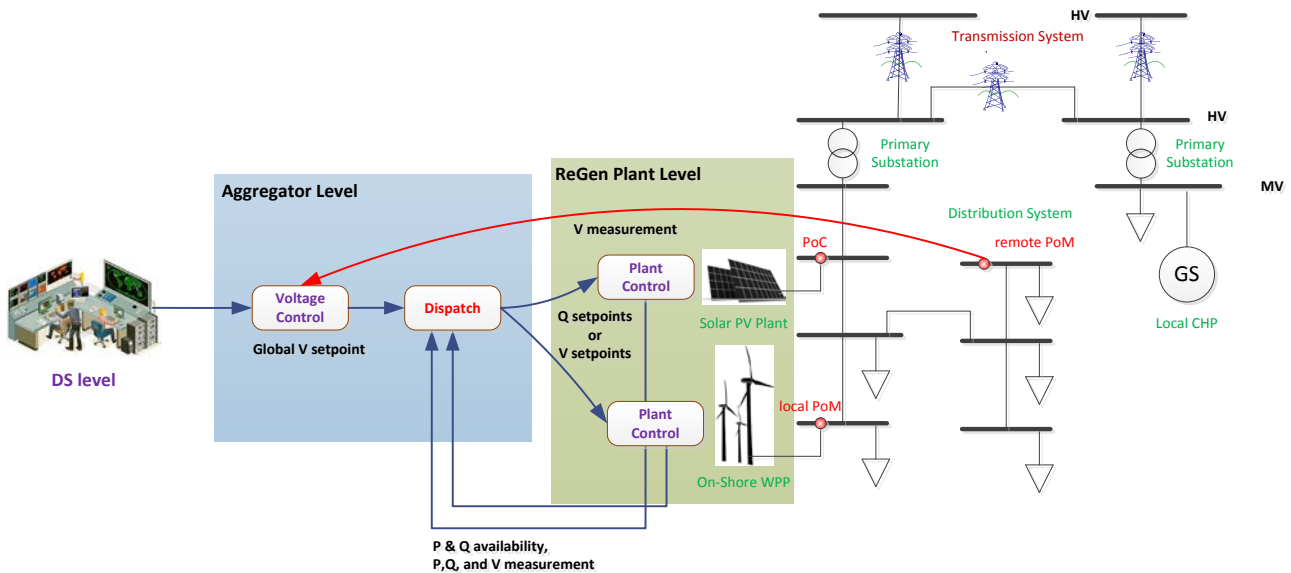


Figure 29. Control coordination by means of voltage control

In Figure 29, an example for coordination scheme between the aggregator level and the Regen plant level regarding a secondary voltage control scheme for distribution grids is illustrated. **For voltage control, secondary frequency control, POD, coordination refers to the allocation of resources to deliver a given service, taking into account the real time communication and the whole control levels chain.**

The input of the voltage controller in the aggregator level is a measured voltage signal from remote bus (i.e. PoM). This controlled bus might be a critical bus (i.e. voltage variations are high) where many loads are connected and far away from the substation. In order to support this bus, the voltage controller produces a global voltage/reactive power set point to the dispatcher as well as delivers relevant system data to the *Dispatch* block. Accordingly, the dispatcher can distribute this setpoint to every allocated ReGen plant as voltage, reactive power, or powerfactor setpoints. The dispatcher’s inputs can be the available active and reactive power together with active/reactive power/voltage measurement signals from ReGen plants (i.e. PoC or PCC). It is worth noting that *Control Coordination* does not only involve *Portfolio Dispatch*, as it also includes communication properties and a whole control chain targeting to avoid “hunting effects” between the assets, while they are trying to control the voltage profile of the whole feeder. Similar coordination approach can be implemented for POD, either for P or Q, as well as for frequency control provision by ReGen plants, as illustrated in Figure 30. **For fast frequency control, rotor angular control, coordination refers to the scheduling of the assets to provide their contribution to a given service. This scheduling indicate the reserve allocation (how much from each asset), order of their activation and the different moments in time when they are activated (i.e delay their response).**

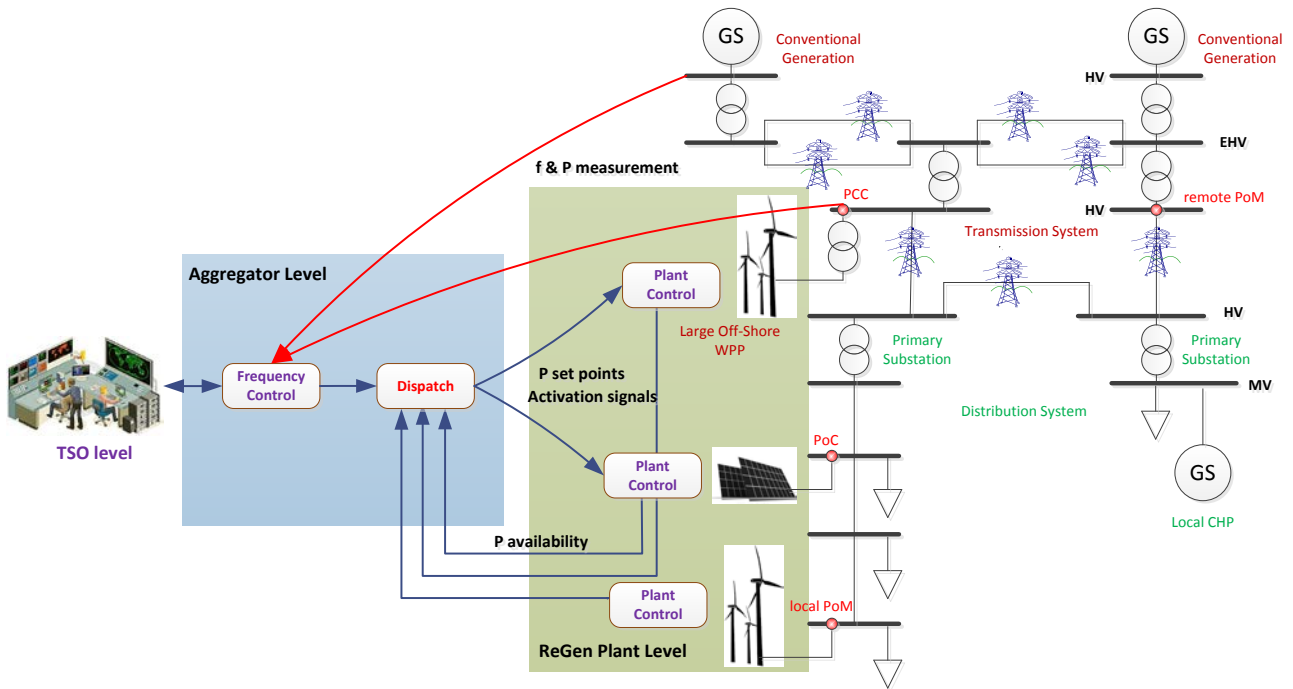


Figure 30. Control coordination by means of frequency control

As mentioned before, these examples illustrate generic possible control coordination schemes for different ancillary services.

As the variability of the output from ReGen plants is the main limiting factor for AS delivery it is crucial that the aggregator level maintains an overview of the state of the portfolio and is able to track service delivery and activate corrective control actions if the assumed boundaries for the ReGen plants are exceeded. It will be investigated how the internal operation of the Aggregator can be implemented and assured.

Additionally, it should be noticed that communication of the real time measurements and of the setpoints plays a crucial role in the control coordination schemes. Coordination properties are therefore outlined subsequently.

3.3.1 Communication Properties

Communication is required for most cases to coordinate and ensure that measurements and set points are correctly exchanged between entities in the system. Several properties of communication are highly relevant, which at the end boil down to the amount of investment required to be done in order to support the control services envisioned. The main communication properties [15] with description are listed in the table below.

Properties	Description
End-to-end delay/ Round-Trip-Time (RTT) [sec.]	End-to-End Delay refers to the time taken by a message to go from source to destination across the entire network, while, the time interval that a message takes to be sent to and receive its acknowledgement from the destination at the source is referred to as Round-Trip-Time. The delays are characterized by <ul style="list-style-type: none"> Distribution of the delay

	<ul style="list-style-type: none"> • Average delay • Maximum delay (boundaries or deterministic) <p>Delays will be characterized at both network and application layer.</p>
Packet loss probability [%]	<p>This refers here to packet losses at the network layer. Packets may also be lost or dropped by the data link or physical layer, but in any case those losses will be detected also at the network layer. Different communication technologies have different impact on the losses at the two lowest layers and relate thus mostly to the evaluation of the Access Networks (AN), while buffering and routing mechanisms impacts the losses at the network layer and thus relates to the Wide Area Network (WAN) cases.</p> <p>Further, impact of packet losses on the transport layer, depends on the two types of commonly used protocols:</p> <ul style="list-style-type: none"> • User Datagram Protocol (UDP): Dropped packets are just dropped. The application must handle this by itself. • Transmission Control Protocol (TCP): When packets at network or lower layers are dropped for some reason, this is being detected by TCP via timeouts and lack of acknowledgement packets. TCP will retransmit lost data. Therefore, packet loss probability is leading to either prolonged end-to-end delays or lost connection (whereas new connections needs to be re-established). The latter effect requires system software to be able to automatically do this.
Jitter [sec.]	<p>This metric is defined as a variation of the end-to-end delay. Different definitions exist, but often a normalized standard variation between average end-to-end delay is used. This metric does not make sense for networks providing deterministic delays, but is used for stochastic networks and for performance metric when performing prioritization of packets.</p>
Range [km]	<p>The range of network in this work is a determining factor on whether a service can be executed within layer two boundaries, or if layer three has to be applied for multi hop. Also this metric is related closely to the topology of the network. This has implications for what type of performance metrics that can be achieved</p>
Security [*]	<p>This metric is simply a note on how sensitive the data being exchanged is to being exposed to malicious attacks, and should be regarded more as a note. The most desirable properties of a secure network communication include confidentiality, authentication, message integrity and non-repudiation. Security is, in some cases, rationale enough to do the investment in private fiber connections, which then also affects other parameters of communication.</p>
Traffic pattern [*]	<p>The pattern of which entities communicate is essential for the</p>

	performance of network. For example, periodic control intervals that require periodic measurements may lead to huge bottle necks if measurement data is transmitted at the same time from various sources. If the system is not de-synchronized or capable of handling bursts of data, the communication often suffers great or completely breaks down.
Scale [number]	The number of sources that need to interact is critical as it affects the overall data communication patterns, and thereby, traffic patterns metric. If only one sensor needs to support one controller, then exchanging a few bytes of data for measurements and for set points is trivial for most networks unless there are extreme timely deadlines. Overhead from protocols also increases significantly with number of sources and may give ground for piggy bagging of data to trade delay into efficiency.
Communication Channel Capacity	It is the highest rate of information that can be transmitted through a channel. While designing a communication link between two entities it is important to model a channel and estimate the amount of information that it can pass through, keeping in mind the effects of channel attenuation, noise induced as well as the non-linear effects.

In addition to the above mentioned communication properties, there are certain other properties to be considered while developing a communication link between two plant controllers. For instance, Propagation Delay, Transmission Delay, Processing Delay, Queueing Delay, Channel Bit Error rate (BER), Congestion Loss, Corruption Loss, Packet error rate, Message size [bits], Buffer size in messages. These are typically metrics related to specific layers in the OSI model, but the goal in this section is to map all these metrics into the two first mentioned metrics: end-to-end delay as a stochastic variable and packet loss probability.

Since the investment in obtaining a deterministic network is quite high, one must practically invest in own private lines, e.g. a fibre cable(s), which after all the cost of digging etc. is also prone to faults like being cut, for example. On the other hand, redundant systems implemented often in multi-purpose networks offers general robustness towards such failure, are also shared and therefore stochastic delays must be tolerated.

The following table from [16] summarizes some of the key network requirements, in general, for different applications used in smart grids:

Table 8: Summary of key network requirements for different smart grid applications.

Application	Network Requirements				
	Bandwidth	Latency	Reliability	Security	Backup Power
AMI	10-100 kbps/node, 500 kbps for backhaul	2-15 sec	99-99.99%	High	Not necessary
Demand Response	14kbps- 100 kbps per node/device	500 ms-several minutes	99-99.99%	High	Not necessary
Wide Area Situational Awareness	600-1500 kbps	20 ms-200 ms	99.999-99.9999%	High	24 hour supply
Distribution Energy Resources and Storage	9.6-56 kbps	20 ms-15 sec	99-99.99%	High	1 hour
Electric Transportation	9.6-56 kbps, 100 kbps is a good target	2 sec-5 min	99-99.99%	Relatively high	Not necessary
Distribution Grid Management	9.6-100 kbps	100 ms-2 sec	99-99.999%	High	24-72 hours

In particular, all these communication properties depend upon the defined scenario as well as the controller in use. Therefore the key research perspectives in RePlan with respect to network are to determine such limits and configurations for specific networks to support the selected services and functionalities in RePlan. With such a table, it is possible to approach network operators with a set of requirements useful for agreements, or allow energy companies to construct and operate their own private networks efficiently

Table 9: Requirements for network to support RePlan services

Service	Connection Between		Delay	Packet loss	Jitter	Range	Security	Traffic pattern	Scale
Voltage Control	DSO Control Center	Plant Control							
Frequency Control	TSO Control Center	Plant Control							
Rotor angle Stability Control	TSO Control Center	Plant Control							

*Meaning all the stuff you would expect from a secure socket session

3.3.2 Dispatch Methods

3.3.2.1 Dispatch methods for voltage control/reactive power control

Reactive power mainly from the power electronic devices is the power source on providing voltage / reactive power control to improve the efficiency on transferring energy. Therefore, the technical constraints of a ReGen unit on providing reactive power are the maximal capacity of the power inverter and the current produced active power. Other constraints may come from the grid by measuring the grid states. The aggregator receives the request from the DSO or the TSO regarding the volume and the activating period. The control function transforms the information to a set point for the dispatch method to match. The prediction of power generation from ReGen plants is updated by an external prediction source (may be independent from all roles in this diagram or integrated with relevant ones). The dispatch method should be able to derive the optimization constraints from all the inputs, and calculate the optimal dispatch results for ReGen plants.

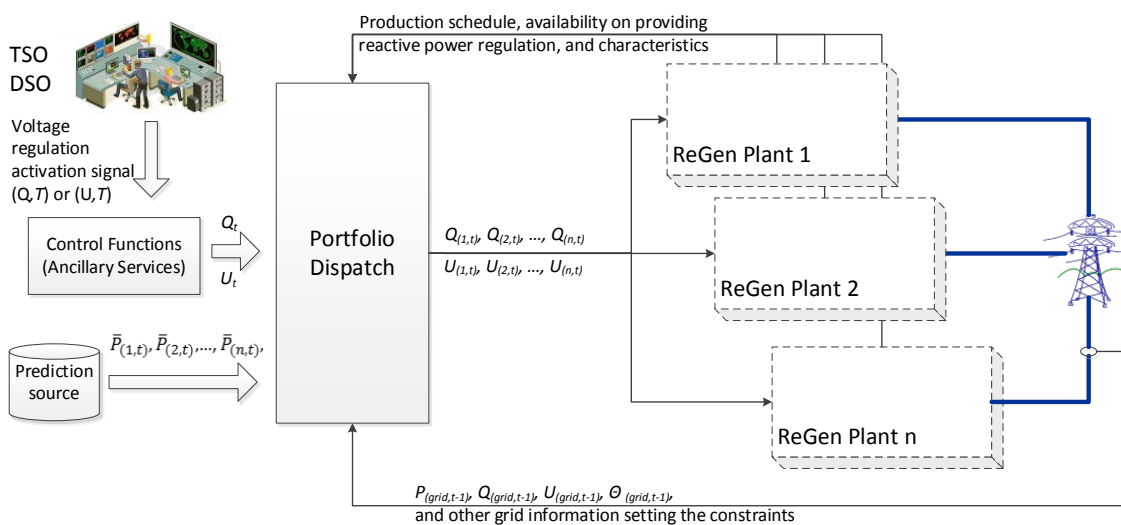


Figure 31. Flow chart of reactive power control.

3.3.2.2 Dispatch methods for secondary frequency control

Active power production from ReGen units can be used for providing secondary frequency control. There are two scenarios for ReGen units:

- ReGen units always produce as much as they can. Therefore, they can only provide down regulation by curtailing their power production.
- ReGen units are asked to produce active power proportional to their maximal production. In such case, they are able to provide two directional secondary frequency controls by up or down regulating their production.

The technical constraint of a ReGen unit on providing active power service is the maximal active power production. Other constraints may come from the grid states. The aggregator receives the request from the DSO or the TSO regarding the volume and the activating period. The control function transforms the information to a set point for the dispatch method to match. The prediction of power generation from ReGen plants is updated by an external prediction source (may be independent from all roles in this diagram or integrated with relevant ones). The dispatch method should be able to derive the optimization constraints from all the inputs, and calculate the optimal dispatch results for ReGen plants.

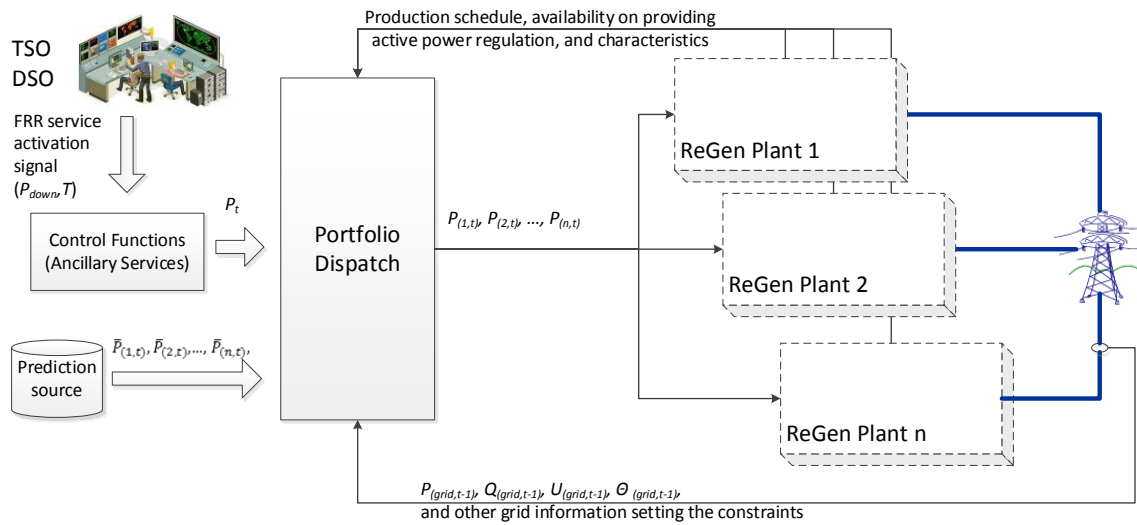


Figure 32. Flow chart of secondary frequency control

4 ReGen Plant Control Specifications

This section describes the ReGen plant control specifications for each AS, are mentioned in the Chapter 2. These control specifications are valid for Plant Control (L0) level. For the upper control levels (L1 and L2) the specifications need to be made according to the selected control concept (e.g. centralized / decentralized) and depending on the control coordination.

4.1 Voltage/Reactive Power Control

In the context of RePlan, voltage/reactive power control is mainly investigated in the distribution system. This control function aims to control the voltage at the MV buses in order to increase voltage stability of the distribution grids and also to support the transmission grid. Accordingly, power factor/reactive power control helps DSOs to control more efficiently the reactive power resources in their network while complying with the reactive power requirements of TSOs at HV/MV substations. It is worth noting that the availability of grid information in the distribution grid may have an impact on the control. Assumptions on availability of grid information are necessary to define the voltage control design phase.

4.1.1 Voltage/Reactive Power Control Design Specifications

Plant controllers have to be able to perform a continuously automatic voltage control without introducing any instability over the entire operation range. For voltage control mode, a slope characteristic has to be followed, where the reactive power setpoints are given based on a change in voltage.

The design requirements applicable for both reactive power, power factor and voltage control mode are shown in the following figure, where the specification for the reactive power output response is illustrated.

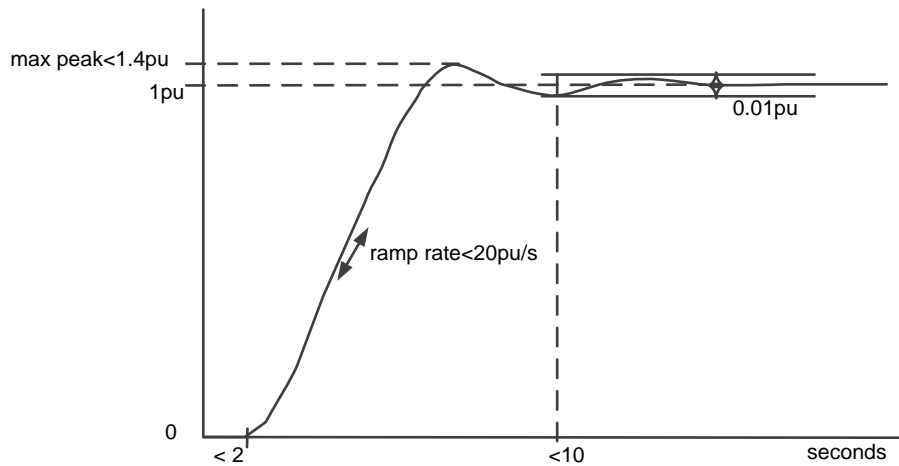


Figure 33. Requirement for reactive power performance

Moreover, as a typical engineering rule the output response should not have an overshoot leading to a larger output than $\sqrt{2}$ pu. Regarding the reactive power performance of WTGs, it should be regarded that rate limiters will typically not allow a larger ramp rate than 20 pu/sec. The control system should have a bandwidth frequency of 5 Hz in order to not excite higher frequency oscillations in the system.

4.1.2 Voltage/Reactive Power Control Functional Specifications

Reference values are obtained from the upper control level (DSO or Energy Aggregator). The control system of the plant receives measurement signals at the PoC and will provide either reactive power or voltage set points to the individual units. An internal dispatching function may be included to optimize the control performance and regard for power losses.

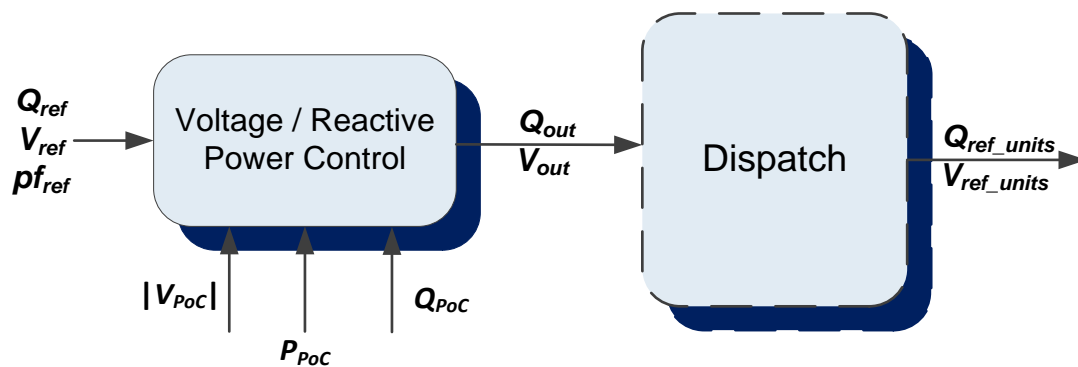


Figure 34. Voltage / Reactive Power Control: Functional description

Table 10. Signals for Voltage / Reactive Power Control

Signal Name	Signal Type	Description
Q_{ref}	Input	Reference value for reactive power
V_{ref}	Input	Reference value for voltage
PF_{ref}	Input	Reference value for power factor
$Q_{out,WPP}$	Internal	Reactive power reference for ReGen plants
$V_{out,WPP}$	Internal	Voltage reference for ReGen plants
V_{PoC}	Output	Measured voltage at PoC
Q_{PoC}	Output	Measured reactive power at PoC
P_{PoC}	Output	Measured active power at PoC

4.2 Frequency Control

In the context of RePlan, frequency control coordination is investigated in the transmission system. The frequency control and the frequency response refer to the fast frequency control (FFC), frequency containment reserve (FCR) control, and frequency restoration reserve (FRR) control [17], as depicted in Figure 35. The origin and the impacts of these control stages on the power system are indicated in Table 11.

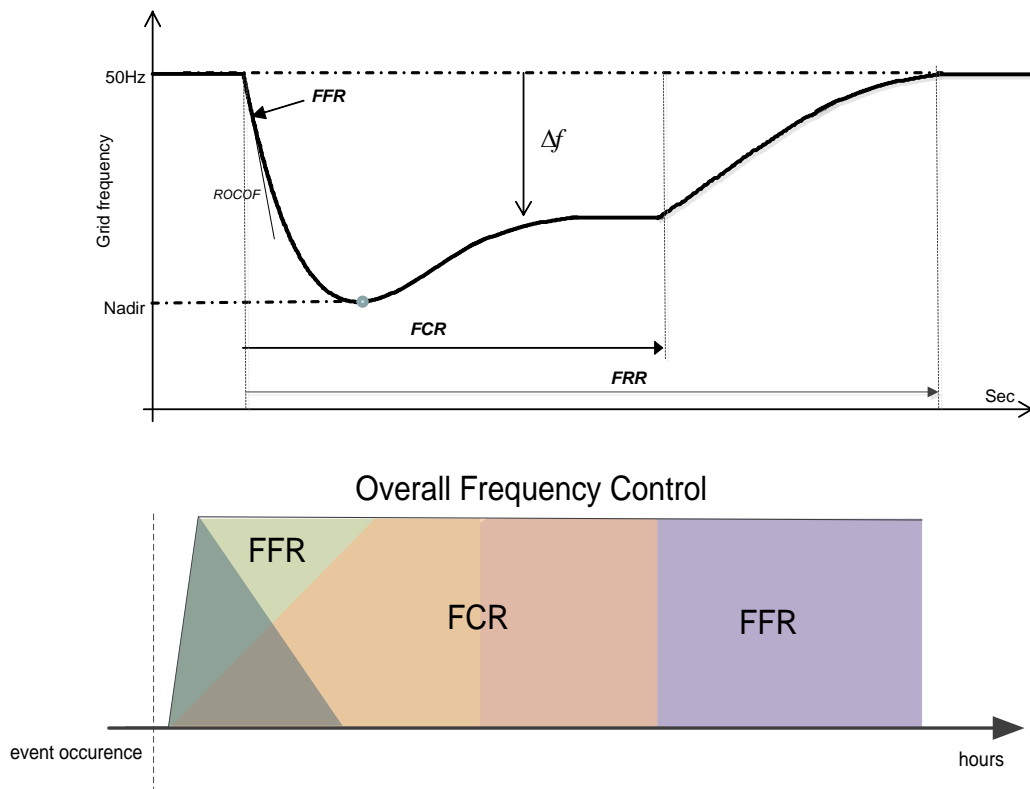


Figure 35: Frequency response contribution stages from ReGen

Table 11: Control stages, impact and origin.

	Control stage	Impact	Origin
1	FFR	Slow down ROCOF providing time for	Kinetic energy from rotor
2	FCR	Bring frequency to a steady state level	Frequency containment reserve
3	FRR	Bring frequency back to its nominal value	Frequency restoration reserve

4.2.1 Fast frequency response (FFR)

FFR is traditionally related to the emulated inertial response or to the fast primary frequency response by ReGen plants. The emulated inertial response in case of WPPscan be extracted from the kinetic energy stored in the actual inertia of wind turbines’ rotor, while the fast primary frequency response requires an active power reserve (both for WPPs and PV plants). FFR reflects the capability of ReGen plants to provide temporarily power support to the system during frequency events. This support is typically limited by ReGen plants’ capabilities during frequency even such as for example wind turbines’ mechanical and electrical control limits and the pre-event wind speed conditions in case of WPPs, and the curtailed power of PV units, clouds and weather conditions in case of PV units.

4.2.1.1 Fast Frequency Response Design Specifications

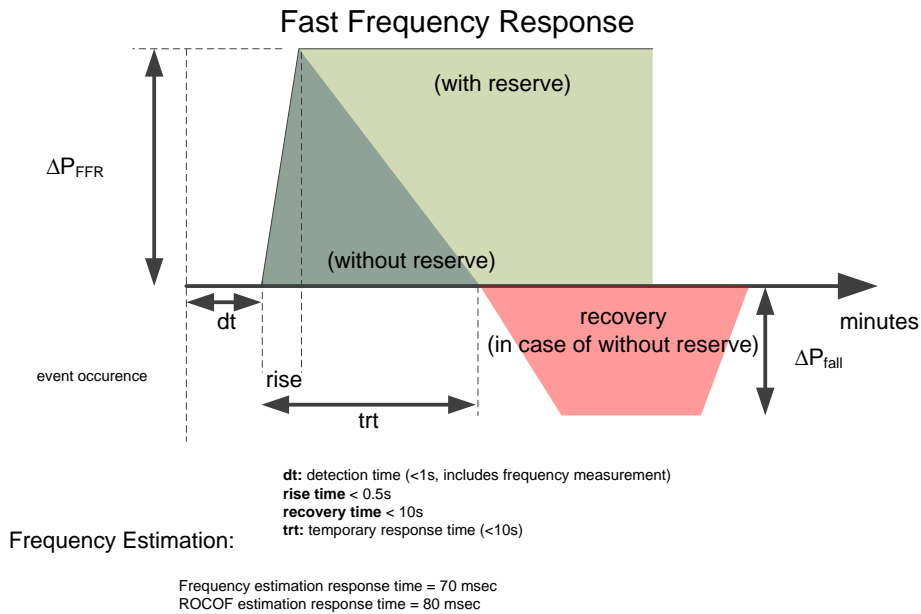


Figure 36: Fast frequency response Design Specification

4.2.1.2 Fast Frequency Response Functional Specification

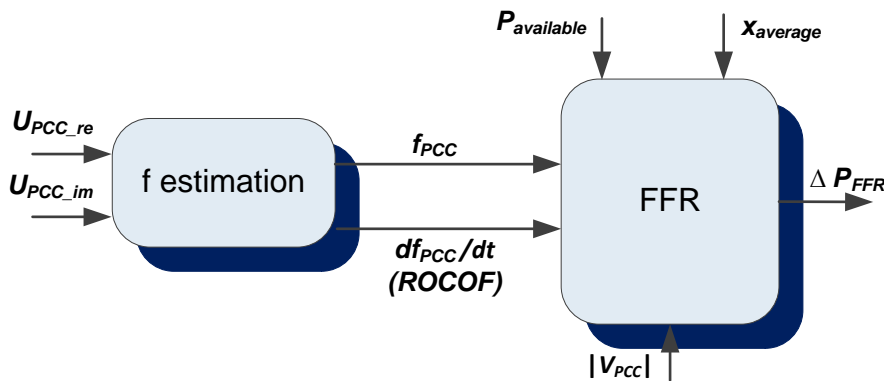


Figure 37: Frequency response Functional Specification

Table 12: Signals for frequency response functional specification.

Signal Name	Signal Type	Description
U_{PCC_re}	Input	Real part of PoC voltage
U_{PCC_im}	Input	Imaginary part of PoC voltage
$ V_{PCC} $	Input	PoC voltage magnitude
f_{PCC}	Internal	Frequency estimated at PoC
df_{PCC}/dt	Internal	Rate of change of frequency (ROCOF) at PoC
$P_{available}$	Input	Available active power of ReGen plants
$x_{average}$	Input (Optional)	-average wind speed in WPP or -solar irradiation/partial shading
ΔP_{FFR}	Output	Active power change for fast frequency response

4.2.2 Frequency Control

Frequency control consists of frequency containment reserve (primary control) and frequency restoration reserve (secondary control). This control can be employed both under and over frequency events.

4.2.2.1 Frequency Containment Reserve (FCR)

FCR refers to the automatic response to frequency changes released increasingly with time over a period of some seconds. It has a full activation time of up to typically 30 s and it is activated automatically.

4.2.2.1.1 FCR Design Specification

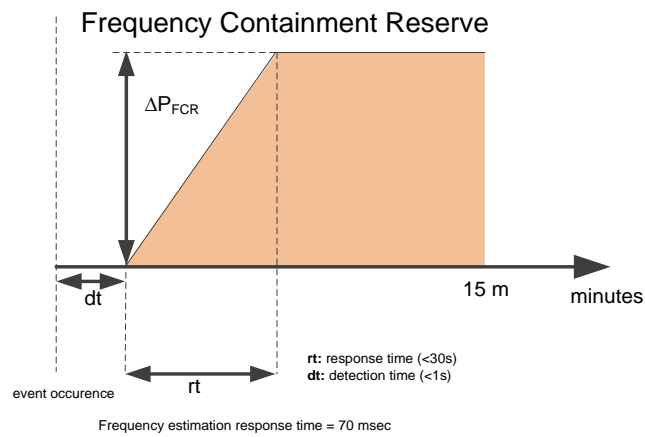


Figure 38: Frequency Containment Reserve Specifications

4.2.2.1.2 FCR Functional Specification

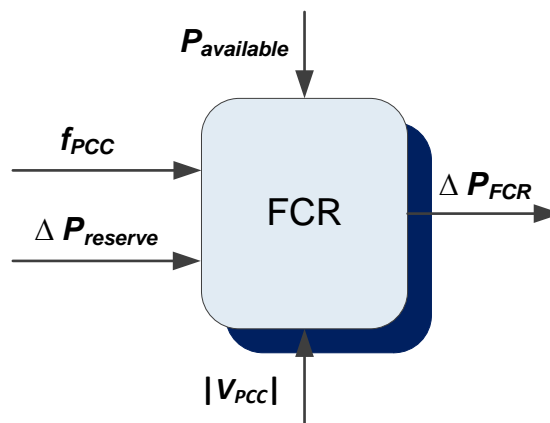


Figure 39: Frequency Control Functional Specification

Table 13: Signals for frequency control functional specification.

Signal Name	Signal Type	Description
f_{PCC}	Input	Frequency estimated at PoC
$\Delta P_{reserve}$	Input	Rate of change of frequency (ROCOF) at PoC
$ V_{PoC} $	Input	PoC voltage magnitude
$P_{available}$	Input	Available active power of ReGen plants
ΔP_{FCR}	Output	Active power change for frequency containment reserve

4.2.2.2 Frequency Restoration Reserve (FRR)

FRR modifies the active power set points /adjustments of reserve providing units in the time-frame of seconds up to typically 15 minutes after an incident in order to perform the function of restoring system frequency to its nominal value and maintaining power system balance into the system.

4.2.2.2.1 FRR Design Specifications

This control can be employed both under and over frequency events.

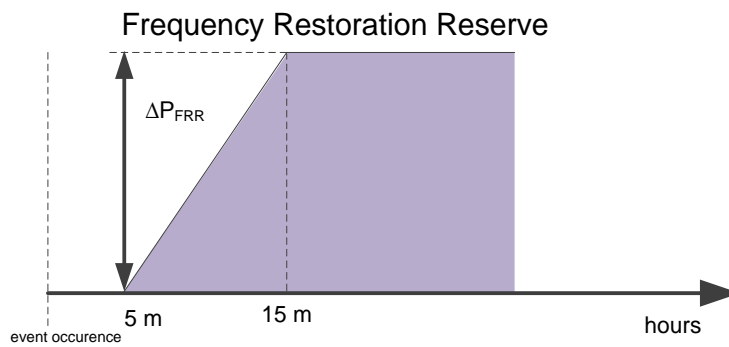


Figure 40: Frequency Restoration Reserve

4.2.2.2.2 FRR Functional Specification

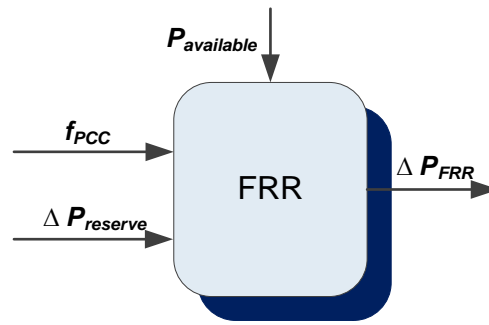


Figure 41: Frequency Restoration Reserve Functional Specification.

Table 14: Signals for frequency restoration reserve functional specification.

Signal Name	Signal Type	Description
f_{PCC}	Input	Frequency estimated at PoC
$\Delta P_{reserve}$	Input	Rate of change of frequency (ROCOF) at PoC
$P_{available}$	Input	Available active power of ReGen plants
ΔP_{FRR}	Output	Active power change for frequency restoration reserve

4.3 Rotor Angle Stability Support (RSS)

As described in RePlan deliverable D1.2, the RSS feature from ReGen plants increase the small signal and rotor angle stability of power systems similar to the power system stabilizers in the conventional power plants. In the context of RePlan, RSS control coordination is investigated in the transmission system..

4.3.1 RSS Design Specification

As indicated in Chapter 2, there are no specific ancillary service requirements for rotor angle stability support from power plants. The capability to damp oscillations is obligatory in conventional power plants with the installation of a power system stabilizer (PSS). For the ReGen plants, the general design specifications can be given as follows:

- To improve the damping of the oscillatory mode (>5%)
- To damp inter-area or local modes of the conventional power plants (frequency range: 0.2-2Hz)
- To utilize the active power or the reactive power with a remote or local measurements

4.3.2 RSS Functional Specification

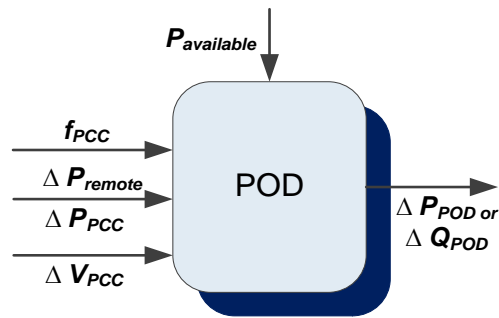


Figure 42: Frequency Restoration Reserve Functional Specification.

5 ReGen Models

This section describes the ReGen models to be used in RePlan, namely the wind turbine generator (WTG) model, the aggregated wind turbine generator model, wind power plant (WPP) model as well as the aggregated photovoltaic PV plant (PVP) model.

5.1 WTG Model

The Type 4B WTG model, described in detail in [18], [19] is used in RePlan project. The model, depicted in Figure 43, is an RMS simulation model, which follows the basic structure of the Type4B IEC standard model including additionally a set of adjustments in order to make the model suitable not only for short term voltage stability but also for active power and frequency control WTG capability studies.

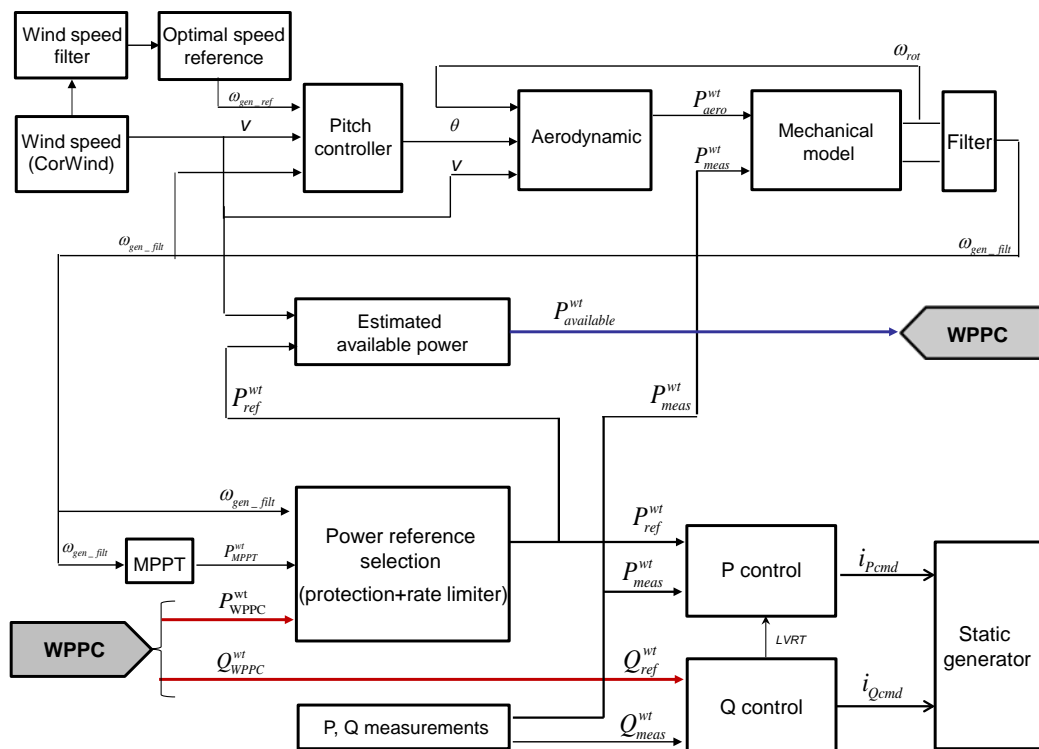


Figure 43: Overview of the WTG model.

The extension of the model includes the wind speed variability, the aerodynamic behavior of the rotor, the wind turbine's power availability, the pitch controller, the maximum power point tracking (MPPT), the optimal speed reference and power reference selection blocks, as well as the wind turbine limits.

The WTG model can either be excited by an event in the grid such as a short-circuit, loss of generation or by a change in a WTG reference value from the wind power plant controller (WPPC). WTG can receive online reference values for active power, reactive power and voltage from the WPPC.

Figure 43 also depicts the interface signals between the WTG model and the wind power plant controller (WPPC). The active and reactive power WTG controllers receive inputs from WPPC, i.e. like active and reactive power setpoints, while the WTG model sends information on the available wind power to WPPC. The initialization of the WTG model is done in consistency with the initialization of the grid model and the wind power plant (WPP), being dependent on its mechanical and electrical parameters.

5.2 Aggregated WTG Model

Type4A + aggregated collector system + wind speed (wind power fluctuation)

The aggregated WTG model, described in details in [19], is used in RePlan project. The aggregated model includes representation of instantaneous wind speed, aerodynamics, pitch actuation, drive-train kinetics, and a dynamic estimation of turbine's available power. The WPP is assumed as a single unit, thus the internal dynamics in the collector system of the wind power plant are omitted.

Figure 44 shows the principle of the aggregation method, which includes both an electrical system aggregation and a wind speed aggregation. The aggregation of the electrical system (i.e. the generators and

the transformers) is performed based on a single up-scaled power procedure, i.e. the aggregated WPP model is an up-scaled power WTG model, while the collector system is aggregated by changing the transformer, the cable sizes and parameters to include the losses and voltage variation.

An aggregated (equivalent) wind speed is calculated and fed into a single up-scaled power WTG model to further calculate an equivalent aggregated WPP power. The equivalent wind speed is an average of individual wind speed time series at the wind turbine level, generated by the CorWind model taking into account the spatial and temporal correlation of wind speeds across the n turbines in WPP. The evaluation of the WPP aggregated method, described in [19] shows that WPP model fed by the equivalent wind speed can correctly represent the behavior of a WPP in power system studies targeted in RePlan project.

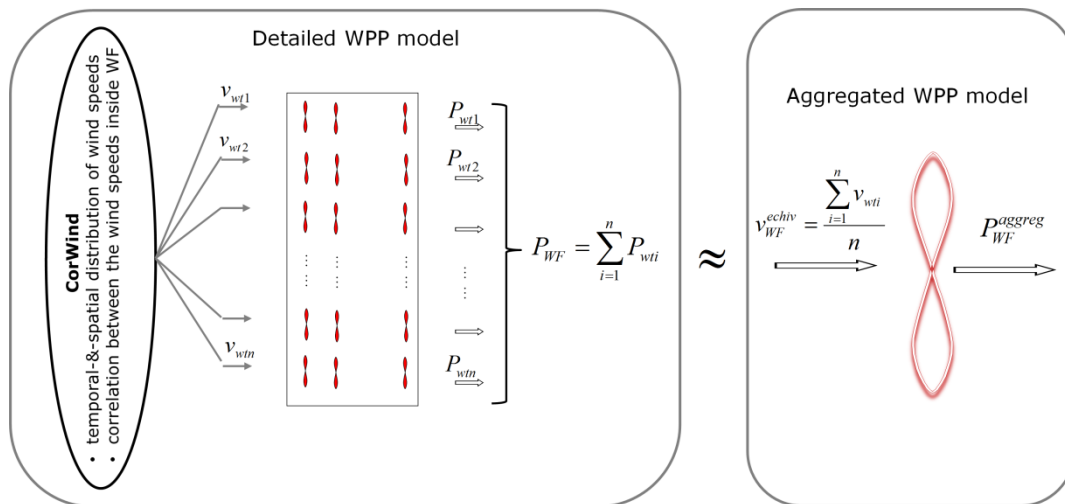


Figure 44: Principle of WPP aggregation method [19].

5.3 WPP Model

A simplified WPP supervisory control is illustrated in Figure 45. It contains a WPP services block and the power controller itself, which includes two separated control loops: one for the active power control and the other for the reactive power control. WPPC controls the power production of the whole WPP by sending out active and reactive power setpoints to the aggregated WTG model. These power setpoints are defined based on measurements, available power information and on specific required control services.

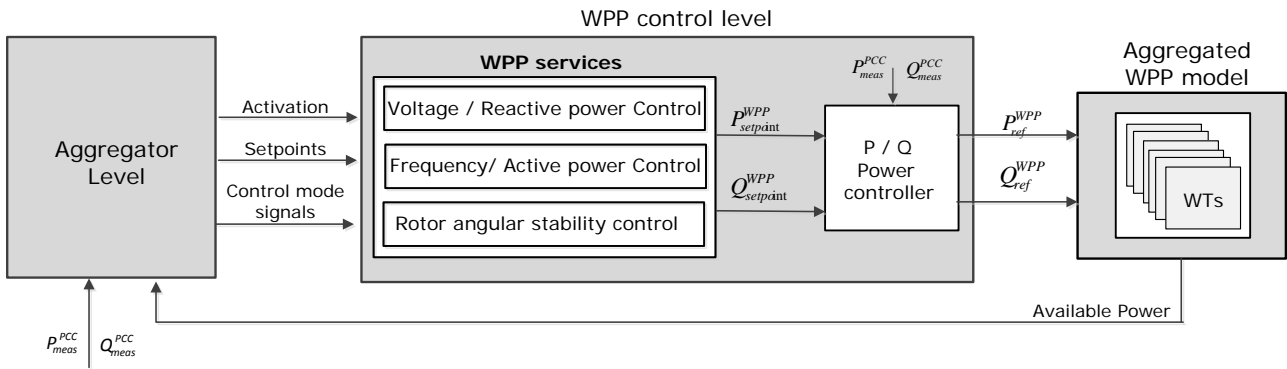


Figure 45: WPP control level.

The block diagram of the voltage and reactive power controller modelled in RePlan project is illustrated in Figure 46 and follows the control structure suggested in the IEC 61400-27-1 [20]. The output of the controller can be either a reactive power reference or a voltage reference depending on the selected control mode. The parameters of the controller are depicted in Table 15 as described in [20].

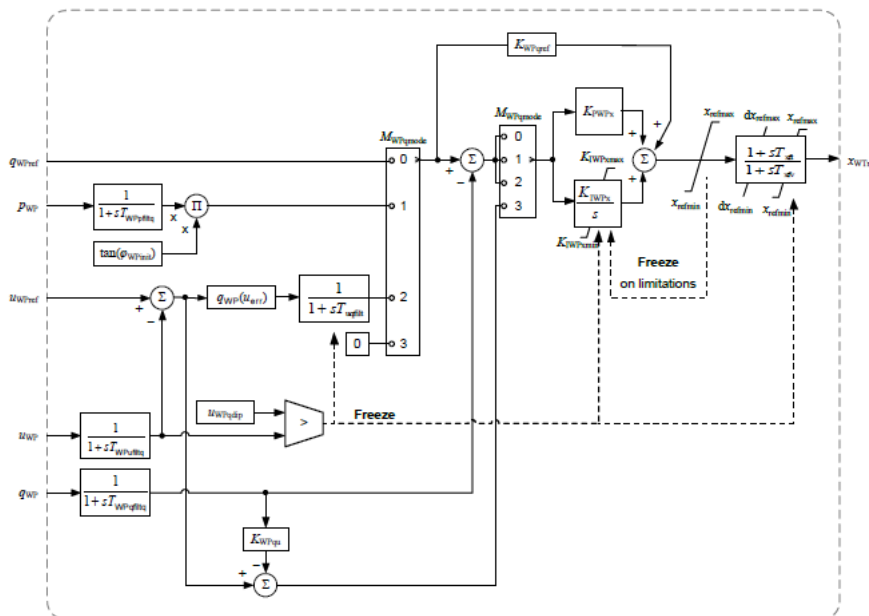
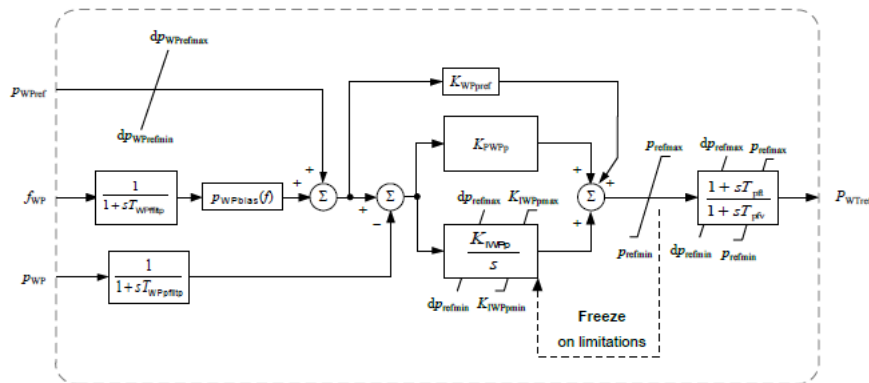


Figure 46: WPP reactive power controller [20]

Table 15: Parameters used in the voltage and reactive power control model [20].

Symbol	Base unit	Description
x_{refmax}	P_n or U_n	Maximum x_{WTref} (q_{WTref} or Δu_{WTref}) request from the plant controller
x_{refmin}	P_n or U_n	Minimum x_{WTref} (q_{WTref} or Δu_{WTref}) request from the plant controller
T_{sft}	s	Lead time constant in reference value transfer function
T_{sfv}	s	Lag time constant in reference value transfer function
K_{PWPx}	-	Plant Q controller proportional gain
K_{IWPx}	s^{-1}	Plant Q controller integral gain
K_{WPqu}	$\frac{U_{WPn}}{P_{WPn}}$	Plant voltage control droop
$T_{WPufiltq}$	s	Filter time constant for voltage measurement
$T_{WPqfiltq}$	s	Filter time constant for reactive power measurement
$T_{WPPfiltq}$	s	Filter time constant for active power measurement
T_{uqfilt}	s	Filter time constant for voltage dependent reactive power
u_{WPqdip}	U_{WPn}	Voltage threshold for UVRT detection in q control
$q_{WP}(u_{err})$	U_n/P_{WPn}	Look up table for the UQ static mode.
K_{WPqref}	P_{WPn}/P_n	Reactive power reference gain
$K_{IWPxmax}$	$P_{WPn}/P_n/s$	Maximum reactive Power/voltage reference from integration
$K_{IWPxmin}$	$P_{WPn}/P_n/s$	Minimum reactive Power/voltage reference from integration
dx_{refmax}	P_{WPn}/s	Maximum positive ramp rate for WT reactive power/voltage reference
dx_{refmin}	P_{WPn}/s	Maximum negative ramp rate for WT reactive power/voltage reference
$M_{WPqmode}$	-	Reactive power/voltage controller mode (0 –reactive power reference, 1- power factor reference, 2- UQ static, 3 voltage control)

The block diagram of the WPP active power controller modelled in RePlan project is illustrated in Figure 47 and follows the control structure suggested in the IEC 61400-27-1 [20]. The output of the controller is the active power reference to the aggregated WTG model. The parameters of the controller are depicted in Figure 47 as described in [20].


Figure 47: WPP active power controller [20]

5.4 Aggregated PVP model

The PVP model is developed according to the Type 4A WTG model, where only the characteristics of the grid connected converter are represented. The model, depicted in Figure 48, follows the basic structure of

the Type 4A IEC standard model including some additions to regard the solar irradiance, the MPPT and the inverter efficiency of the PVP.

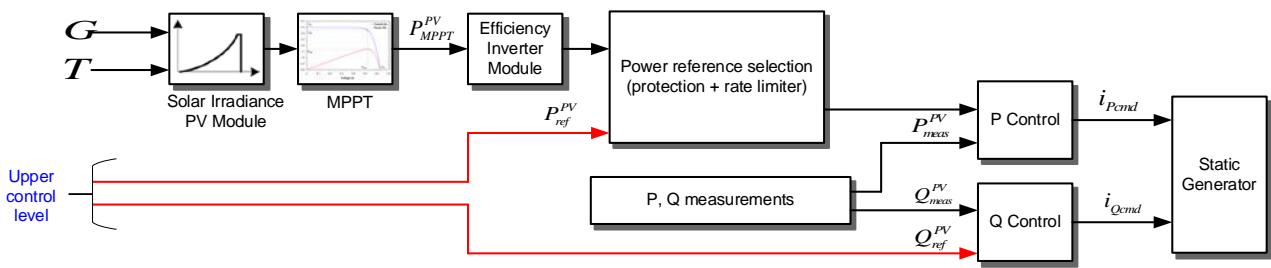


Figure 48. Overview of the PVP Model

The output power of a single PV module is a function of environmental temperature T and solar irradiance G . For the sake of simplification and since the focus of RePlan is not layed on the individual units within a ReGen plant, the solar irradiance is assumed to be equal for all PV modules, although for huge PVPs there are differences due to cloud movement. In this way, the blocks shown in Figure 48 represent an aggregated model of the PVP.

The MPPT has a response time of tenths or hundreds of milliseconds depending on the applied MPPT technique [21].

Figure 48 also depicts the interface between the PVP and the upper hierarchical control level. While for the aggregated WTG model setpoint and measurement signals are exchanged with the WPP, the PVP is directly interfaced with either Aggregator Control (L1) or Control Centre (L2).

The PVP model can either be excited by an event in the grid such as a short-circuit, loss of generation or by a change in a reference value upper control level.

The initialization of the PVP model is done in consistency with the initialization of the grid model being dependent on its electrical parameters.

6 ICT Models

A network consists of communicating devices or computers connected directly/indirectly to allow electronic communications. Although these communicating devices can be directly connected to each other using wired or wireless connections, central devices like hubs, switches, or routers are generally required to connect more devices, especially for long distance communication, as in case of smart grids. In the following a brief overview of communication technology is provided.

6.1 Types of Physical Medium

The signal transmitted by the controller, usually, passes through a number of transceivers to reach to the control center. Layer one and two of the OSI model describes the key functionality of exchanging bits between two entities within a single communication technology, and forms the basis for all communication, and is elaborated in this subsection.

Data frames are propagated between two entities in the form of electromagnetic waves or pulses through a physical medium which as a consequence therefore is classified into the following two categories:

- a) **Guided Medium:** As the name implies, the signal propagates within a guided/solid medium. The examples of such medium are fiber optic cables, twisted pair copper cables, coaxial cables etc.
- b) **Unguided Medium:** The signal propagates unguided within the atmosphere. The examples of such this medium are satellite radio spectrum, terrestrial radio spectrum etc.

It is not necessary for a medium to remain the same throughout the path between a controller and the control center, however, a change in medium (even to the same) has implication on end-to-end performance (more about that later). A little description of different types of physical media is given below:

6.1.1 Guided Media:

- a) **Twisted-Pair Copper Cables:** Such cables are commonly used for internet access in residential areas at tens of Mbps. One type of twisted-pair cable (UTP) is used for small networks called LANs that provide a data rate from 10 Mbps to 10 Gbps depending on its thickness and the distance between transmitter and receiver. The present twisted-pair cables can provides data rates of 10 Gbps up to hundred meters.
- b) **Coaxial Cables:** Cable television systems commonly use such cables to facilitate users with different entertainment channels as well as internet access at rates up to tens of Mbps. These cables can also be used as a guided shared medium.
- c) **Fiber Optics:** Optical fiber transmits the intended data in the form of light pulses through very thin and flexible hair-like structures called threads, providing data rates up to tens to hundreds of Gbps. The high data rates, immunity to electromagnetic interference, very low signal attenuation (up to tens of kilometers) and other characteristics have made fiber optics the best source of communication as compared to other physical media. But these cables are usually not preferred in short range communication due to the high cost of equipment and installation. Fiber optic cables are most commonly employed in the backbone of internet as well in overseas links.

6.1.2 Unguided Media:

- a) **Terrestrial Radio Channels:** The signals within this medium are carried through the atmosphere within the electromagnetic spectrum without any guided/physical path. These radio channels are preferred for long distance communications where it is not feasible to have cable connections. The signals can penetrate through walls of houses and other buildings and cars, thus providing access to the mobile systems; however the ability of penetration is highly dependent on the carrier frequency used. The radio channels are classified into three categories depending on the distance they cover:

1. **Short Distance Radio Channels** (one to two meters):

Used for wireless headsets, keyboards, medical devices etc. For example Bluetooth

2. **Local Area Radio Channels** (ten to a few hundred meters):

Used in wireless LAN technologies e.g. WiFi (IEEE 802.11)

3. **Wide Area Radio Channels** (tens of kilometers):

Used in cellular access technologies e.g. 3G, 4G, Long Term Evolution (LTE)

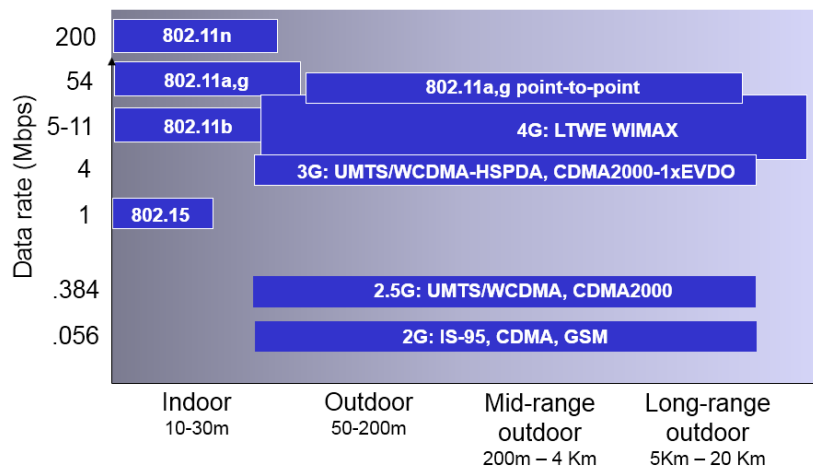


Figure 43 Characteristics of Selected Wireless Link [22]

- b) Satellite Radio Channels:** This radio channel uses a satellite for communication between two entities providing data rates up to hundreds of Mbps. Since, the signal has to cover a large distance from ground to the satellite and then back to the ground, this trip introduces a propagation delay of about 280ms in the communication [22]. These are mostly used in areas where there is no access to the cable based internet or DSL.

Communication networks in smart grids are usually built using unguided wireless technology, keeping in mind the long distances between the controllers and the control centers. (These networks are usually referred to as access networks). The following table from [23] compares different communication technologies used in smart grids:

Table 16: Brief overview of different communication technologies and their key properties

Technology	Standard/protocol	Max. theoretical data rate	Coverage range
<i>Wired communication technologies</i>			
Fiber optic	PON	155 Mbps–2.5 Gbps	Up to 60 km
	WDM	40 Gbps	Up to 100 km
	SONET/SDH	10 Gbps	Up to 100 km
DSL	ADSL	1–8 Mbps	Up to 5 km
	HDSL	2 Mbps	Up to 3.6 km
	VDSL	15–100 Mbps	Up to 1.5 km
Coaxial Cable	DOCSIS	172 Mbps	Up to 28 km
PLC	HomePlug	14–200 Mbps	Up to 200 m
	Narrowband	10–500 kbps	Up to 3 km
Ethernet	802.3x	10 Mbps–10 Gbps	Up to 100 m
<i>Wireless communication technologies</i>			
Z-Wave	Z-Wave	40 kbps	Up to 30 m
Bluetooth	802.15.1	721 kbps	Up to 100 m
ZigBee	ZigBee	250 kbps	Up to 100 m
	ZigBee Pro	250 kbps	Up to 1600 m
WiFi	802.11x	2–600 Mbps	Up to 100 m
WiMAX	802.16	75 Mbps	Up to 50 km
Wireless Mesh	Various (e.g., RF mesh, 802.11, 802.15, 802.16)	Depending on selected protocols	Depending on deployment
Cellular	2G	14.4 kbps	Up to 50 km
	2.5G	144 kbps	
	3G	2 Mbps	
	3.5G	14 Mbps	
	4G	100 Mbps	
Satellite	Satellite Internet	1 Mbps	100–6000 km

These above listed communication systems form a layer two network, in which certain properties are maintained, e.g. broadcast mechanisms, but also limitations in terms of transmission. Interconnection of such networks forms a layer three network (most known is the Internet or more generically a WAN) and is described in the following sub section.

6.2 Types of Networks based on Switching Techniques

To extend a layer two network and to ensure end-to-end connectivity the different communication technologies are linked together (in principle, all combinations are possible, but of course specific implementation details leads to different options and behaviors). To do this, two different concepts can be used for making two end-nodes communicate in a network i.e. Packet Switching and Circuit Switching.

6.2.1 Packet Switching:

Networks using packet-switching transfer data in the form of discrete and small blocks of bits called packets, based on the destination address in each packet.

Once converted into bits, the message is further broken into packets of predefined length. As soon as the path becomes available, each packet seeks for the most efficient route within the network, and may take a

different route. Its header (containing destination address) guides it to the destination. At the receiver side, these packets get back together in the proper sequence to make up the message.

6.2.2 Circuit Switching:

Networks using circuit-switching require a dedicated point-to-point connection for making two nodes communicate and reserve this dedicated channel for the whole communication period. In such networks, communication signals pass through several intermediate devices before a connection is established. Once the connection is established, no other network traffic can use those links/channels until this communication is over. The early telephone networks used circuit switching to establish call between the two telephones. Meaning that before the callers started their conversation; a connection was established between them reserving a link with constant transmission rate.

One of the obvious advantages of this type of switching is that it provides a continuous transfer of signal without anyone else sharing the same link. But, this becomes the cause of inefficiency of circuit switching, as there might be periods of silence during the call where there is no exchange of information, still no one else is allowed to make use of it. So, circuit switching can be a good choice for voice applications but for big amount of data transmission, packet switching proves to be the efficient choice.

6.3 Types of Delays in Packet Switched Networks

Ideally, one may want to transfer maximum amount of data from source to destination, without any loss. But in real communication it is not possible. Instead, the amount of data transferred per second (also known as throughput) is constrained due to a number of delays that occur while data passing from one node to another all the way to its destination. According to [22], the most significant delays that the packet suffers from are:

6.3.1 Processing Delay:

This is the time spent to scan the whole data packet for its header and then deciding where to direct it. In high-speed routers, these delays are usually on the order of microseconds or less [22].

6.3.2 Queueing Delay:

When a packet enters a node, it may find other packets in a queue, waiting for their turn to be transmitted onto a link. The length of this queue determines the time it has to wait for its own turn. So, if there is no queue in the node, there will be no queueing delay. Greater the length of queue, higher will be the delay. Queueing delays ranges from some order of microseconds to milliseconds [22].

Since the queueing capacity of a node is finite, it cannot put all the packets in a queue. Thus, if a packet arrives at a node and finds a full queue, it will be dropped by that node [22].

6.3.3 Transmission Delay:

The time a node takes to transmit all bits of a packet into the link is called transmission delay. It is determined by taking ratio of number of bits to the rate at which number of are transferred per second. These delays are usually range from microseconds to milliseconds [22].

6.3.4 Propagation Delay:

Now that all the bits of a packet are pushed into the link, they need to propagate to the other node in the network. So, propagation delay is the time this packet takes to propagate through the link to the other node. The speed of propagation usually depends upon the link's physical medium. For big networks like WANs, propagation delays take on the values in milliseconds [22].

The total nodal delay is a sum of all these delays. i.e.

Nodal Delay = Transmission Delay + Queueing Delay + Transmission Delay + Propagation Delay [22]

6.4 Types of Networks on the Basis of Network Architecture

The access networks can be classified into two categories based on the functional relationship that exist between the network elements i.e. Client-Server and Peer-to-Peer Architecture.

6.4.1 Client-Server Architecture:

In a client-server environment, data is stored, managed and controlled on a centralized, high speed server that is accessible by all the clients. In case of smart grids, the plant controllers send data to the control centers that takes necessary actions as per requirement. The advantages of client-server architecture include centralized resource management, improved security, server level security and scalability.

6.4.2 Peer-to-Peer Architecture:

A peer-to-peer network architecture allows two or more communicating devices to pool their resources together without the involvement of a server. Though, such networks do not require a network administrator, they are fast and inexpensive to setup and maintain, but, lack centralized administration and lack of security and are thus, not suitable for large networks.

6.5 Types of Networks on the Basis of Scale/Area

Networks can be classified into following three broad categories based on the scale/area that they cover:

6.5.1 Local Area Network

A network that covers a small physical area is called local area network (LAN). This small physical area may include a home, an office, or small group of buildings, such as a college, or an airport etc. Current LANs are most likely to be based on Ethernet or WiFi technologies. For example, in automatic meter reading (AMR) a wireless LAN manages to read the smart meters of a small area and send those to the control center.

6.5.2 Metropolitan Area Network

A network that connects two or more local area networks together without extending beyond the boundaries of the immediate town/city is called metropolitan area network (MAN). Several intermediate devices like routers, switches and hubs are used to connect LANs to create a metropolitan area network.

6.5.3 Wide Area Network

A wide area network (WAN) covers a broad area like metropolitan, regions or countries. Different public communications links or routers are used for this purpose. Internet is the most well-known and common example of a wide area network WAN.

6.6 Types of Networks on the Basis Physical Topologies

The configuration of cables, computers, controllers and other peripherals in a network are referred to as its physical topology. Following are the basic types of physical topologies used in a network:

6.6.1 Bus Topology:

In this type of topology all network nodes are connected to a common transmission medium (called bus, backbone or trunk) which has exactly two endpoints. The data in this network is transmitted over the bus between the two endpoints, with all connected nodes having access to this data, virtually, simultaneously.

6.6.2 Star Topology:

Here, each network node is connected to a central node with a point-to-point link. In this network, data transmitted between nodes is first transmitted to this central node that may retransmit that data to some or all of the other nodes in the network.

6.6.3 Ring Topology:

As the name implies, ring topology forms a ring of nodes as each network node is connected to two other nodes in the network, with the first and last nodes connected to each other. In this network, data transmitted between nodes travels from one node to the next in a circular manner, in a single direction only.

6.6.4 Mesh Topology:

In mesh topology, each network nodes is connected to all other nodes in the network with a point-to-point link. Thus it becomes possible for data to be simultaneously transmitted from any single node to all other nodes.

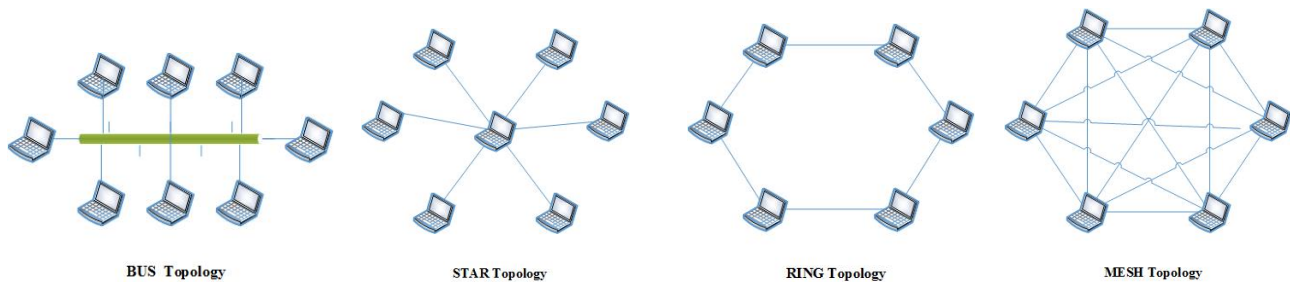


Figure 49 Network Topologies

6.7 Network Protocols and Layered Architecture

There are a number of protocols implemented by different software and a set of hardware that are involved in the transmission of data from source to destination. To have a better idea of the data travelling within the network, network designers have organized these protocols, software and hardware in different layers, each belonging to a specific layer.

There are two types of layered architectures i.e. the Internet Protocol stack and Open System Interconnection (OSI) reference model. The Internet Protocol stack consists of five layers (Application layer, Transportation Layer, Network layer, Data-Link layer, Physical layer) while OSI model consists of seven layers (Application layer, Presentation layer, Session layer, Transportation Layer, Network layer, Data-Link layer, Physical layer). OSI layered architecture model was developed by the ISO (International Organization for Standards) and describes how information from a software application in one communicating device, moves through a network medium to a software application in the other in more detail as compared to the Internet Protocol stack.

The following table highlights responsibilities and protocols description of the OSI referenced model:

Table 17: Tabel of different OSI layers, their functionality and related protocols

Layers	Data Unit/ Protocols	Responsibilities
Application	Data Unit → Messages Protocols: <ul style="list-style-type: none"> ○ HTTP, HTML (Web) ○ FTP, SMTP ○ MPEG, H.323 (Audio/Video) ○ IMAP, POP (e-mail) 	<ul style="list-style-type: none"> - Provides interface to application programs - Program to Program transfer of information.
Presentation		<ul style="list-style-type: none"> - Converts system specific format to network format

		- Provides encryption and compression of data
Session		- Facilitates starting, handling and ending of connection between the nodes - Synchronize related streams of data
Transport	<p>Data Unit: Segments</p> <p>Protocol:</p> <ul style="list-style-type: none"> • Transmission Control Protocol (TCP), • User Datagram Protocol (UDP) 	<p>- Reliability</p> <p>- Flow control</p> <p>- Fragmentation</p> <p>- Port numbers are used to differentiate between different applications running on the same node</p> <p>- Accurate delivery, Service quality.</p>
Network	<p>Data Unit: Packets/ Datagram</p> <p>Protocol: Internet Protocol (IP)</p>	<p>- Provides addressing across the internet</p> <p>- Used for routing (determines which path the data takes)</p>
Data Link	<p>Data Unit: Frames using MAC address</p> <p>Protocol: Ethernet (LAN), PPP (dial-up modem)</p>	<p>- Reliable transfer between two nodes</p> <p>- Physical addressing</p>
Physical	Data Unit: Signals/Bits	- Hardware Connections

Figure 50 explains how data travels from one device to the other through a layered architecture.

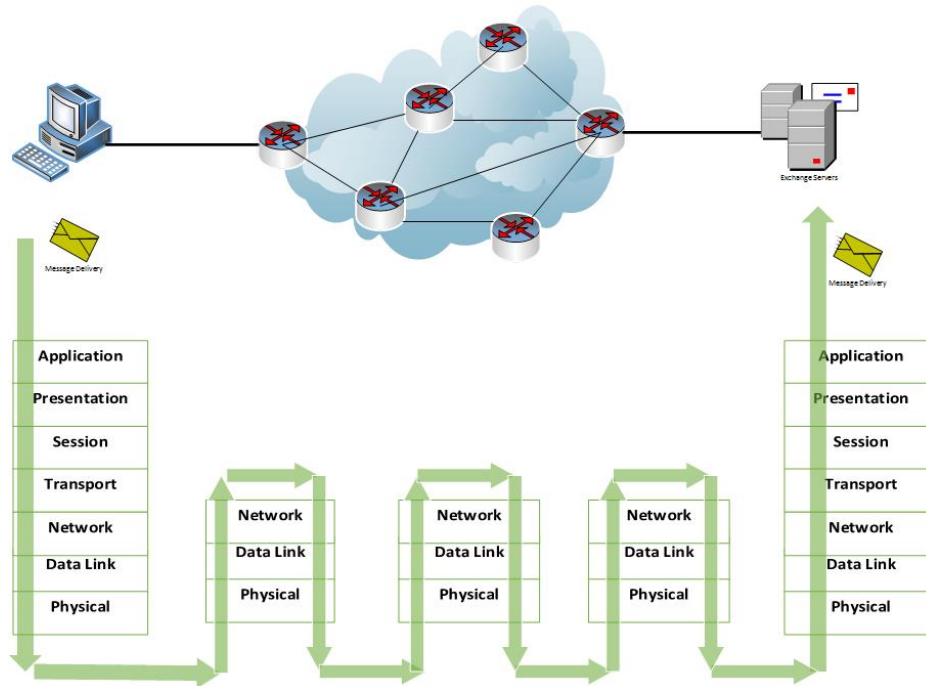


Figure 50 Signal Flow through Layered Architecture

As can be seen in the figure, a message (email or a control signal) is transmitted from a computer to the server. On its way to the destination, the message passes through a series of packet switching devices – routers in this case. Based on the destination address of the packet, each of the router forwards the packets to the next node. These routers are responsible of performing two tasks i.e. forwarding (using a forwarding table that maps destination addresses to its link interfaces) and well as routing (determine a suitable route to the destination). The packets may take different routes to travel to the destination depending upon the traffic on the link.

6.8 Overview of standard protocols used in context of RePlan

To have an overview of the standard protocols used in context of RePlan, there’s a need to highlight the main interaction between elements involved in the network. The communication and control components with the relevant protocols are shown in Figure 45:

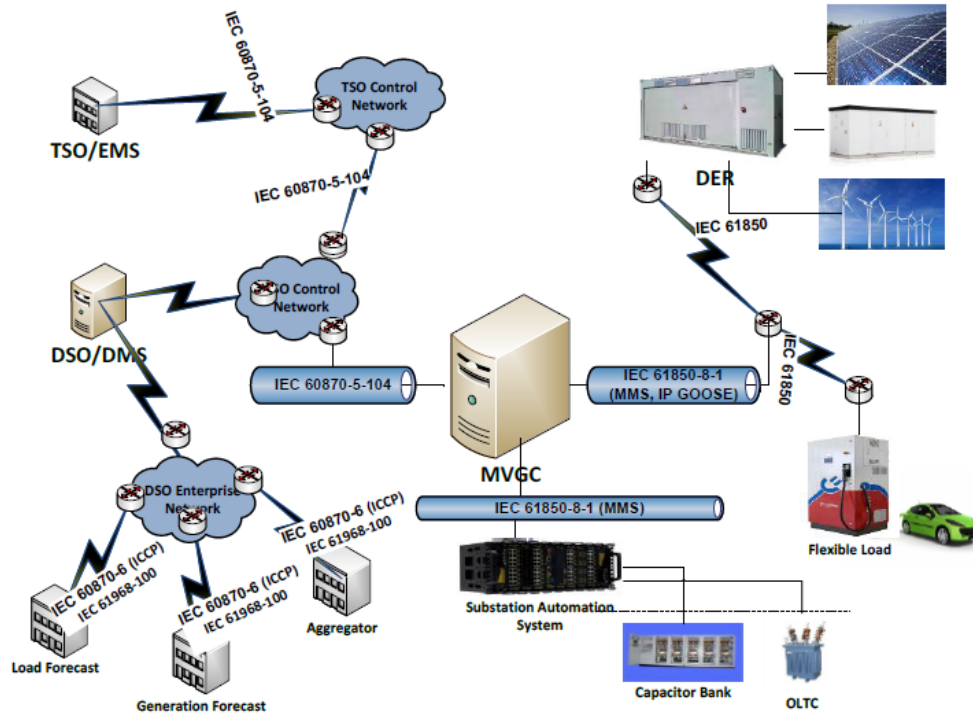


Figure 51 Overview of Standard Protocols [2]

The following table summarizes system's protocol requirements

Table 18: Overview of protocols and requirements to communication networks

Service	Connection between		Standard Protocol	Current Requirements	Notes
Voltage/ Reactive Power Control	DSO Control Center	Plant Control	IEC 60870-5, IEC 61850	Reliable 99.99%	
Frequency/ Active Power Control	TSO Control Center	Plant Control	IEC 60870-5, IEC 61850	Reliable 99.99%	
Rotor Angle Stability Control	TSO Control Center	Plant Control	IEC 60870-5, IEC 61850	Reliable 99.99%	

7 Power System Model

The main goal of RePlan project is to prove that the ReGen plants can contribute to the enhancement of the power system stability, as well as to demonstrate the suitability of the coordination between ReGen plants in the provision of AS in order to enable a resilient power system with high shares of these plants. The first step toward integrating the new control functionalities in ReGen plants is to implement a power

system model which reproduces the necessary grid characteristics for actuation and impact assessment of the coordination between ReGen plants in the delivery of the AS in focus.

In the literature, there are many available generic power system models for different purposes. Since the project is administrated by Energinet.dk, the Danish power system model is convenient to demonstrate large scale impact of the developed control functions and the coordination of these functions. This power system model has the realistic performance regarding the voltage and frequency control in the transmission level. There two main areas in this model; the first area is the West Denmark (DK-1) and the second area is the East Denmark (DK-2). The electrical connections of these two areas to the neighboring countries are illustrated in Figure 52.

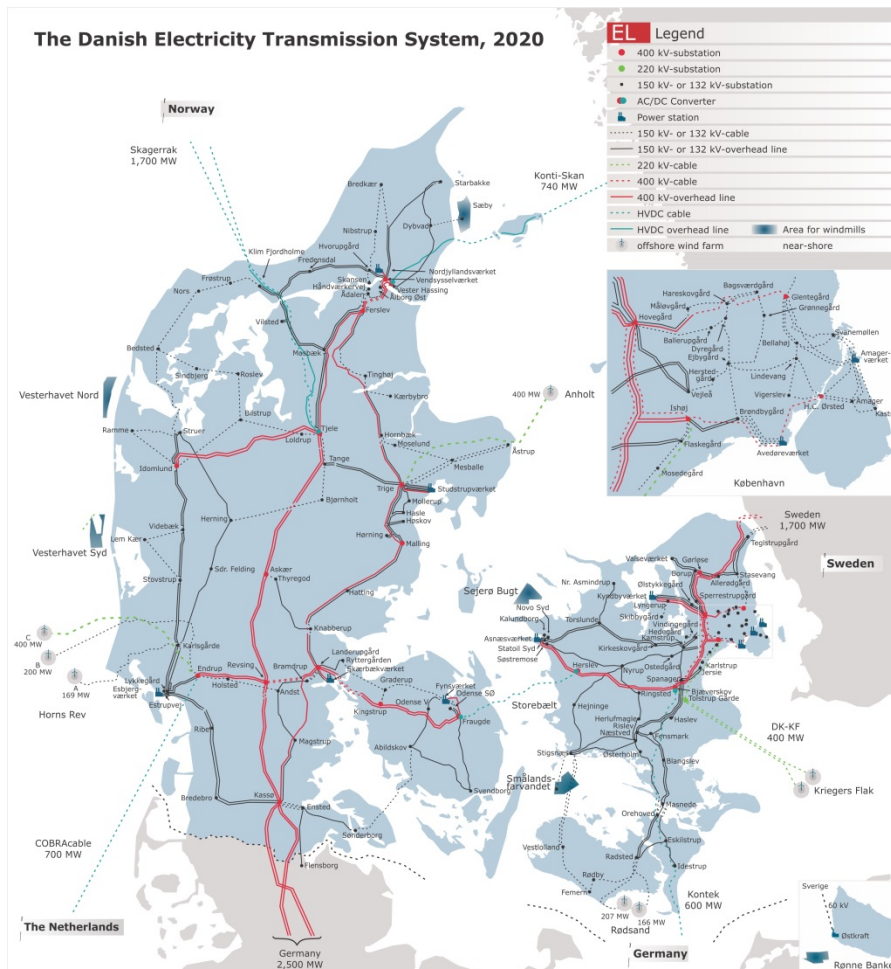


Figure 52: Danish power system

In the project, the focus will be on DK-1 power system model which has synchronous connection to EU grid and HVDC connections to Norway, Sweden and DK-2. With this realistic model, a number of test cases should be defined (e.g. line and generator (N-1) tripping, sudden load change) to impose abnormal conditions on the system and demonstrate various stability phenomena (i.e. frequency, voltage, and small-signal stability). In order to implement these test cases, Energinet.dk and ENTSO-E grid design criteria will be considered [24], [25]. Since ReGen plant integration and coordination studies are targeted, various wind and PV penetration scenarios can be established based on public data from Energinet.dk.

8 Summary

Work Package	Topics	Relevant chapters	Section	Remarks
WP2: Voltage Stability Support	Development of coordinated voltage control strategies	Technical requirements	Section 2.2.2	
		Control Architecture	Chapter 3	
		Control Specifications	Section 4.1	
		ReGen Models	Chapter 5	
	Case studies for coordinated voltage support from ReGen plants	Voltage limits	Section 2.2.1	
		ICT Models	Chapter 6	
WP3: Frequency Stability Support	Development of primary & secondary frequency control features for ReGen plants	Technical requirements	Sections 2.2.3 & 2.2.4	
		Control Architecture	Chapter 3	
		Control Specifications	Section 4.2	
		ReGen Models	Chapter 5	
	Case studies for coordinated primary & secondary frequency support from ReGen plants	Frequency limits	Section 2.2.2	
		ICT Models	Chapter 6	
WP4: Rotor Angular Stability Support	Development of solutions for improving rotor angular stability with ReGen plants	Technical requirements	Sections 2.2.5	
		Control Architecture	Chapter 3	
		Control Specifications	Section 4.3	
		ReGen Models	Chapter 5	
	Case studies for coordinated rotor angular stability support from ReGen plants	Voltage limits	Section 2.2.1	
		Current limits	Chapter 7	
		ICT Models	Chapter 6	
		Power System Model	Chapter 7	
WP5: Verification of AS	Verification of ancillary services in large scale power system (RT-HIL)	Technical requirements	Section 2.2.1	
		In-scope Controls		inputs provided by WP2-WP4
		ICT Models	Chapter 6	further elaborated as part of WP2-WP4
		ReGen Models	Chapter 5	further elaborated as part of WP2-WP4

		Power System Model	Chapter 7	further elaborated as part of WP2-WP4
	Verification of ancillary services in small scale power system (SYSLAB)	Technical requirements	Section 2.2.1	
		In-scope Controls		inputs provided by WP2-WP4

9 Bibliography

- [1] IEC, *Electromagnetic compatibility (EMC) - Part 3-6: Limits - Assessment of emission limits for the connection of distorting installations to MV, HV and EHV power systems.*, 2008.
- [2] "SmartC2Net Use Cases, Preliminary Architecture and Business (D1.1 - version 2)," 30-09-2014.
- [3] "<http://www.elia.be/en/products-and-services/balance>,".
- [4] ENTSO-E, *Network Code for Requirements for Grid Connection Applicable to all Generators*. Brussels, 2013.
- [5] Dr. Jako Kilter, Dr. Ralph Pfeiffer, Sergio Martinez Villanueva, Robert Wilson Helge Urdal, *National Implementation Challenges and Support by ENTSO-E for European Connection Network Codes*. Brussels: 14th Wind Integration Workshop, 2015.
- [6] Energinet.dk, *Technical regulation 3.2.5 for wind power plants with a power output above 11 kW*. Fredericia, 2015.
- [7] Energinet.dk, *Technical regulation 3.2.2 for PV power plants with a power output above 11 kW*. Fredericia, 2015.
- [8] ENTSO-E, *Network Code on Load-Frequency Control and Reserves*. Brussels, 2013.
- [9] Energinet.dk, *Technical Regulation for Thermal Power Station Units of 1.5 MW and higher*. Fredericia, 2008.
- [10] Energinet.dk, "Ancillary services to be delivered in Denmark - Tender conditions," Fredericia, 2012.
- [11] National Grid, "The System Operability Framework (SOF)," 2014.
- [12] The Electric Reliability Council of Texas (ERCOT), "Future Ancillary Services in ERCOT," 2013.

- [13] Hydro Quebec, "Transmission Provider Technical Requirements for the Connection of PowerPlants to the Hydro-Quebec Transmission System," 2009.
- [14] Nordel, *Nordic Grid Code.*, 2007.
- [15] William Stallings, *Data and Computer communications*, 8th ed.: Pearson International Edition, 2009, ISBN-10: 0-13-507139-9 , 2009.
- [16] "COMMUNICATIONS REQUIREMENTS OF SMART GRID TECHNOLOGIES," 2010.
- [17] Han X., Hansen A.D., Løvenstein O.R., Cutululis N.A., lov F. Altin M., "Technical Feasibility of Ancillary Services provided by ReGen Plants," DTU Wind Energy, DTU Wind Energy E-0099 2015.
- [18] Margaris I. Hansen A.D, "Type IV Wind turbine Model," DTU Wind Energy, 2013.
- [19] Altin M., Cutululis N.A. Hansen A.D., "Modelling of wind power plant controller, wind speed time series, aggregation and sample results," DTU Wind Energy, DTU Wind Energy E-0064, 2015.
- [20] "[3]. IEC 61400-27-1 Ed.1. Wind Turbines - Part 27-1: Electrical simulation models for wind power generation – Wind turbines," 2015.
- [21] Ghislain and Bethoux, Olivier and Marchand, Claude and Dogan, Hussein and others Remy, *Review of MPPT Techniques for Photovoltaic Systems*. Laboratoire de Génie Electrique de Paris, 2009.
- [22] Keith Ross and James Kurose, *Computer Networking - A Top-Down Approach.*: PEARSON, 2013.
- [23] Murat Kuzlu, Manisa Pipattanasomporn, and Saifur Rahman, "Communication network requirements for major smart grid applications in HAN, NAN and WAN," *Computer Networks (The International Journal of Computer and Telecommunications Networking)*, pp. 74-88, 2014.
- [24] Energinet.dk. (2008) Netdimensioneringskriterier for net over 100kV.
- [25] ENTSO-E. (2004) Operational Security. [Online]. <https://www.entsoe.eu/publications/system-operations-reports/operation-handbook/Pages/default.aspx>
- [26] D1.1 - version 2 SmartC2Net, "Smart Control of Energy Distribution Grids over Heterogeneous," http://www.smartc2net.eu/public-deliverables/smartc2net-use-cases-preliminary-architecture-and-business-drivers/@@download/document/SmartC2Net_D1.1_v2.pdf September 2014.